

**SERVICE MANUAL
&
PARTS LIST**

**MODEL: HORIZON Memory Craft 9480
QC PROFESSIONAL**

First Edition: 24 July 2023

Modified info.

Modified: 08 August 2023

P10 and 11: "Before replacing the printed circuit board A, copy the data in the board to a USB flash drive.

* Check the clear set mode (refer to page 45)." added.

P11: Replacing Electronic Components "Printed circuit board A" added.

Printed circuit board A connection: P10 → P11

P11 to 44 → P12 to 45

P45: deleted.

INDEX

Changing External Parts

Face cover.....	1
Top cover.....	1
Belt cover.....	2
Base plate.....	3
Base cover.....	3
Bed cover.....	3
Free arm cover.....	4
Front cover.....	6
Rear cover.....	8

Replacing Electronic Components

Printed circuit board A case.....	10
Printed circuit board A.....	11
Printed circuit board A connection.....	11
Printed circuit board F.....	12
Switching power supply.....	13
DC motor.....	14
Thread tension.....	15

Mechanical Adjustment

Feed dog height.....	16
Needle drop position.....	17
Clearance between needle and tip of the rotary hook (method 1).....	18
Clearance between needle and tip of the rotary hook (method 2).....	19
Hook timing.....	20
Needle bar height.....	21
Backlash between hook drive gear and lower shaft gear.....	22
Upper shaft shield plate position.....	23
Upper thread tension.....	24
Tension release mechanism.....	25
Needle threader hook position.....	26
Needle threader release amount for the wire of the hook holder.....	27
Thread drawing lever.....	28
Upper feed dog (1).....	29
Upper feed dog (2).....	30
Upper feed dog (3).....	31
Buttonhole lever position.....	32
Thread cutter.....	33
Presser bar lifter position.....	34
Presser foot lifter stopper position (1).....	35
Presser foot lifter stopper position (2).....	36
Automatic presser foot lifter initializing position.....	37
Presser foot height on needle plate.....	38
Stretch stitch feed balance.....	39
Needle plate switch.....	40
Knee lifter.....	41
Embroidery foot height.....	42

Brightness adjustment.....	43
-----------------------------------	-----------

Touch panel key position adjustment.....	44
---	-----------

Clear set mode.....	45
----------------------------	-----------

PARTS LIST.....	46 to 75
------------------------	-----------------

Changing External Parts

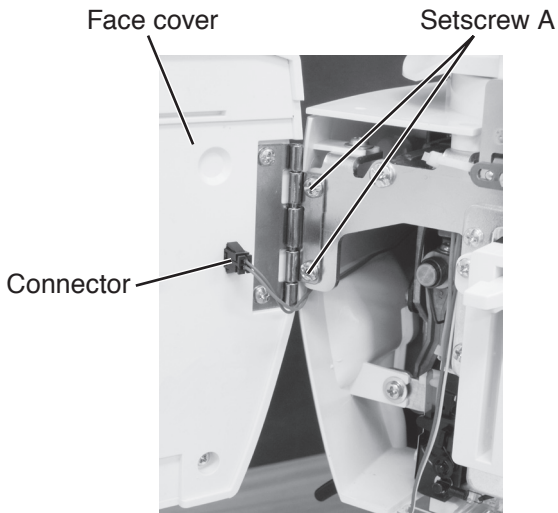

Face cover

To remove:

1. Open the face cover.
Disconnect the connector from the face cover.
Remove the setscrews A (2 pcs.).
Remove the face cover.

To attach:

2. Follow the above procedure in reverse.

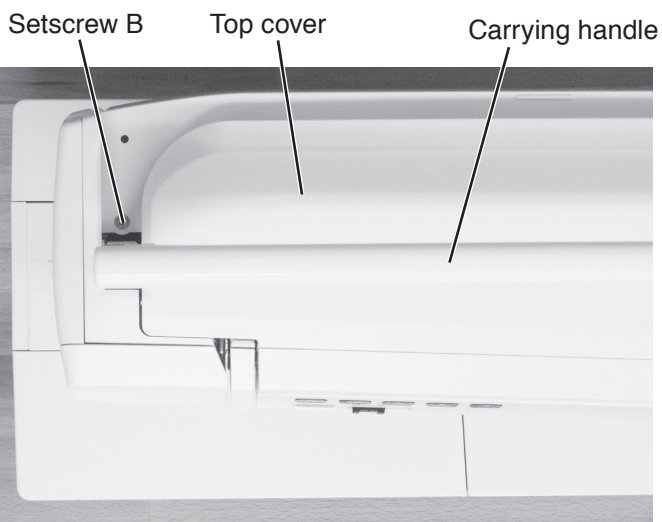

Top cover

To remove:

1. Raise the carrying handle.
Remove the setscrew B.
Lower the carrying handle.

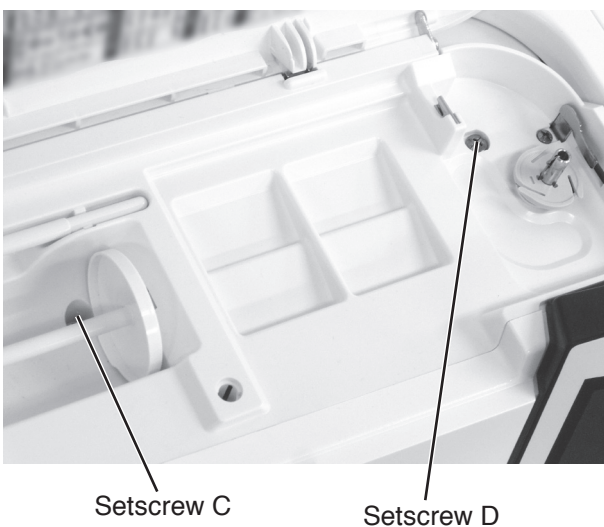

2. Open the top cover.
Remove the setscrew C and setscrew D.
3. Raise the carrying handle and remove the top cover.

To attach:

4. Follow the above procedure in reverse.

Changing external parts



Belt cover

To remove:

1. Raise the carrying handle.
2. Loosen the setscrew A.

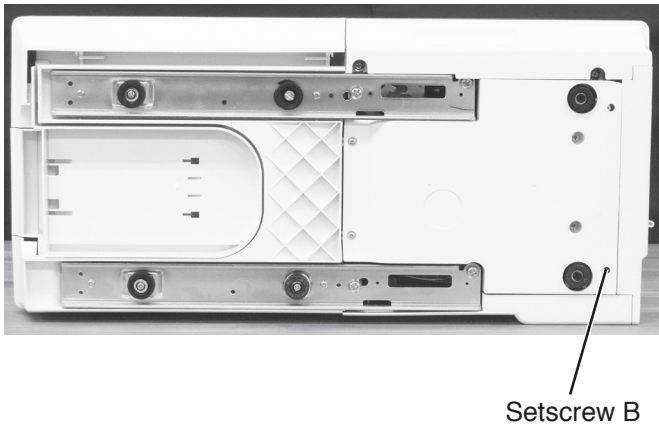

3. Loosen the setscrew B.



4. Remove the caps (2 pcs.) and the setscrews C (2 pcs.).
5. Remove the belt cover.

To attach:

6. Follow the above procedure in reverse.

Changing external parts

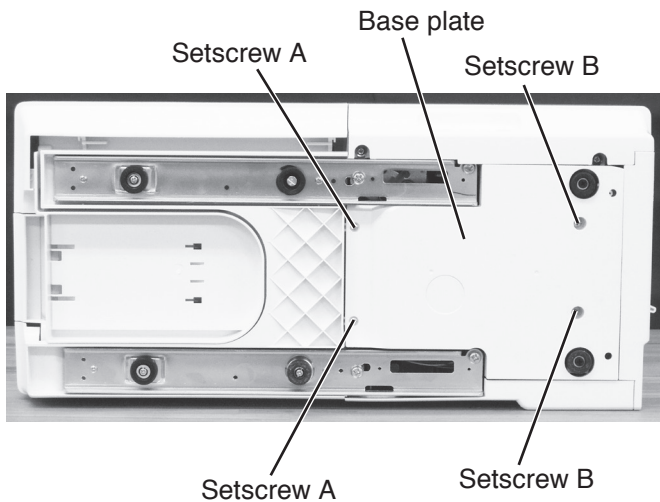

Base plate

To remove:

1. Remove the setscrews A (2 pcs.) and setscrews B (2 pcs.).
2. Remove the base plate.

To attach:

3. Follow the above procedure in reverse.

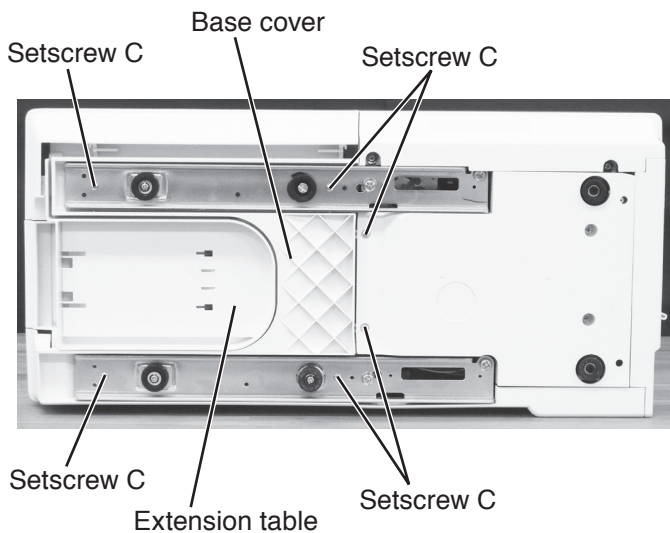

Base cover

To remove:

1. Remove the extension table.
Remove the setscrews C (6 pcs.).
2. Remove the base cover.

To attach:

3. Follow the above procedure in reverse.

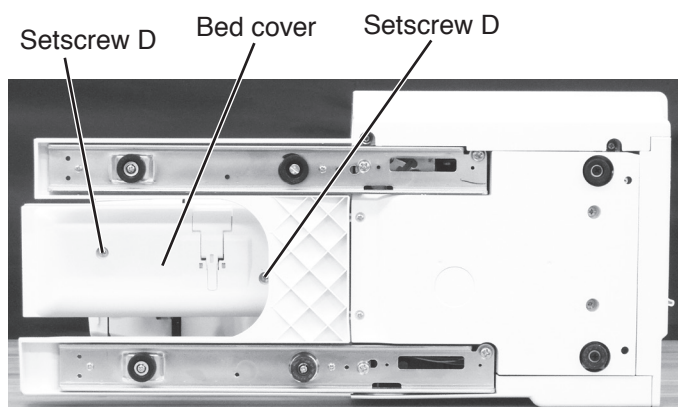

Bed cover

To remove:

1. Remove the extension table.
Remove the setscrews D (2 pcs.).
2. Remove the bed cover.

To attach:

3. Follow the above procedure in reverse.

Changing external parts

Free arm cover

Needle plate

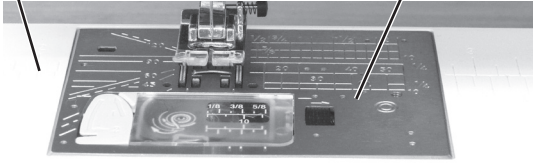

Needle plate release lever

Free arm cover

To remove:

1. Remove the base plate and base cover (refer to page 3).
Push down the needle plate release lever to remove the needle plate.

Pin

Bed cover



2. Remove the pin with the screwdriver.
Remove the bed cover (refer to page 3).

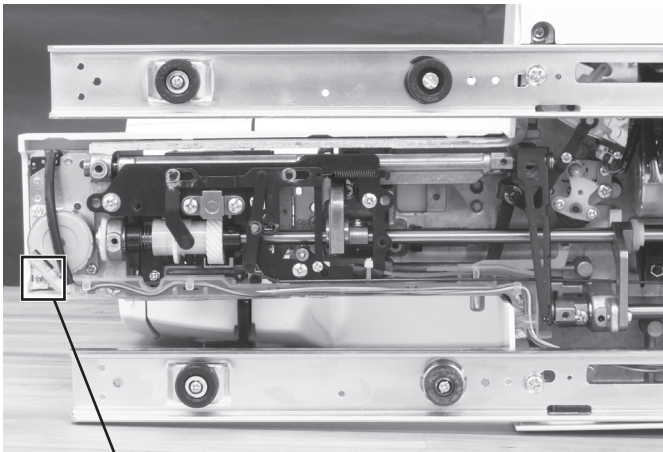

3. Loosen the setscrew.

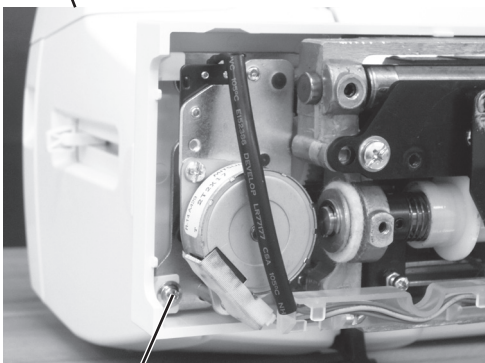

Setscrew

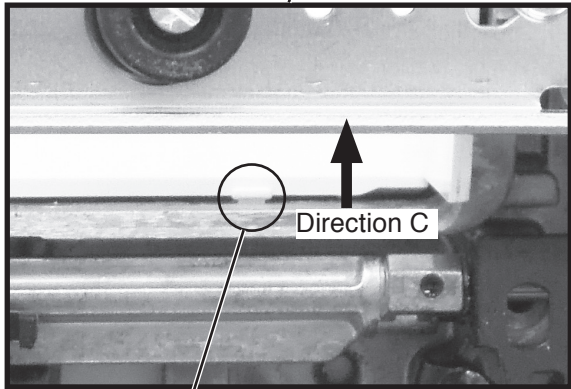
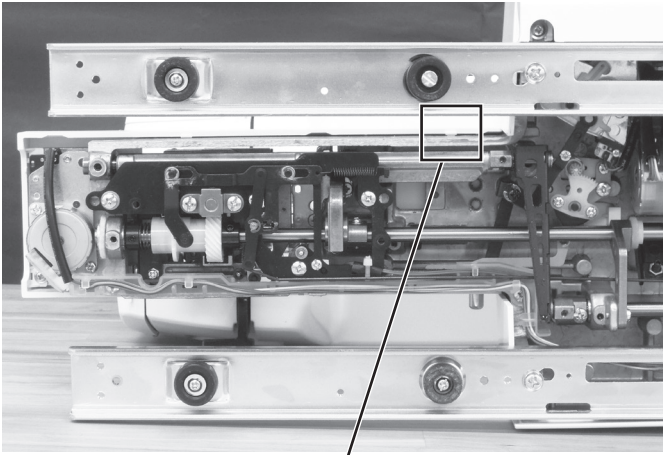

Hook A

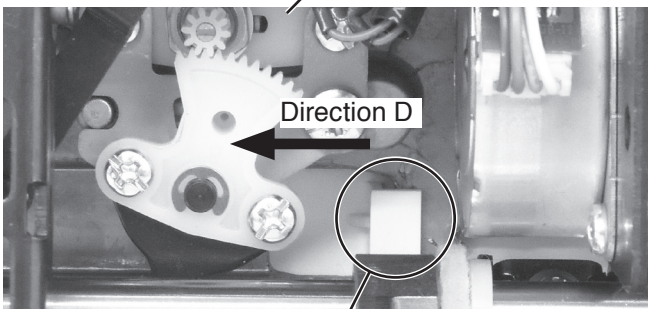
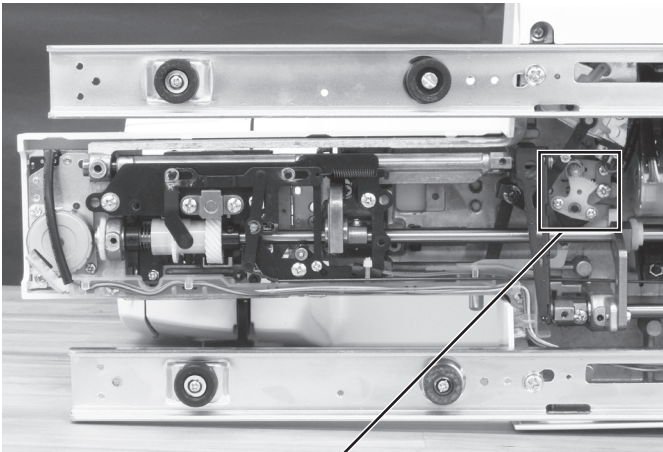

Hook B

4. Unhook the hook A (front side of the free arm) and move the free arm cover to the direction C. Unhook the hook B (inside of the base plate) and move the free arm cover to the direction D.
5. Slide the free arm cover to the left to remove the free arm cover.

To attach:

6. Follow the above procedure in reverse.

Changing external parts

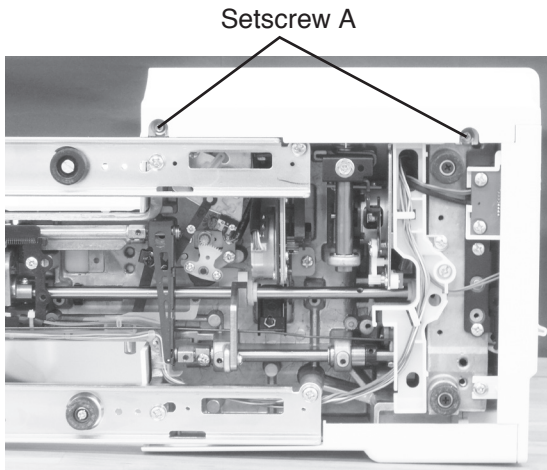

(View from the bottom)

Front cover

To remove:

1. Remove the top cover, belt cover, base plate, base cover and free arm cover (refer to pages 1 to 5).
2. Loosen the setscrews A (2 pcs.).



Setscrew B

3. Loosen the setscrew B.

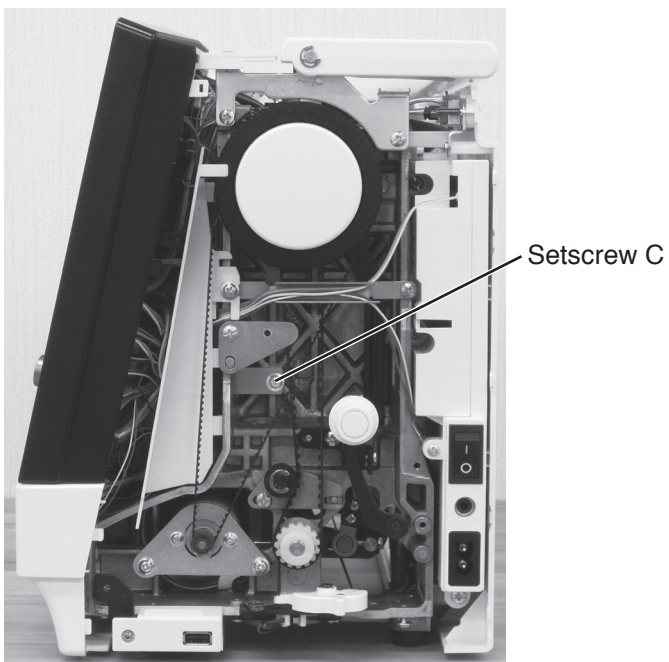

4. Loosen the setscrew C.

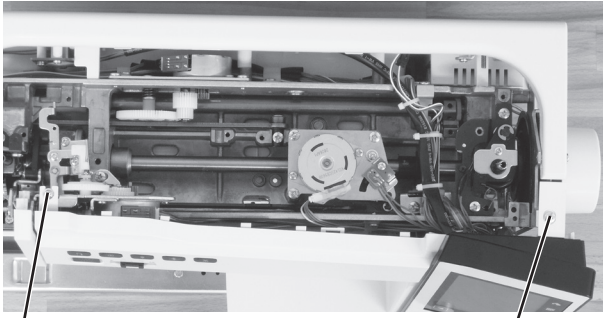

Setscrew D

(View from the top)

Setscrew E

5. Loosen the setscrew D.
6. Remove the setscrew E

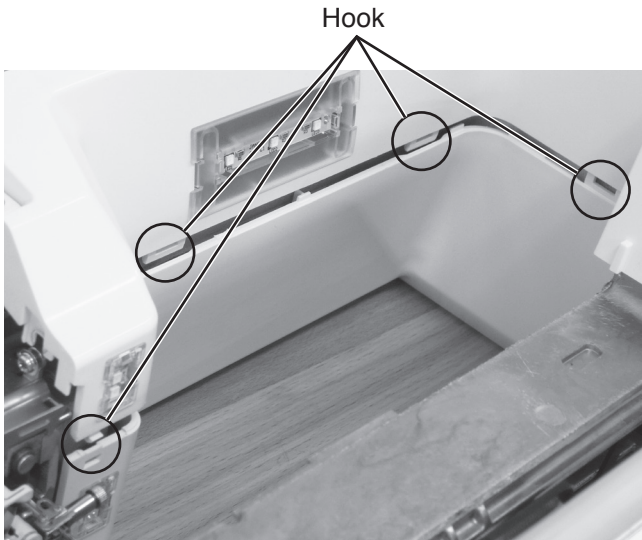

7. Unlock the hooks from the front cover.
Remove the connectors from the circuit board A
(refer to page 11).
Remove the front cover.

To attach:

8. Follow the above procedure in reverse.
Refer to page 11 for how to connect/disconnect the
connectors to the printed circuit board A.

Changing external parts

Face cover

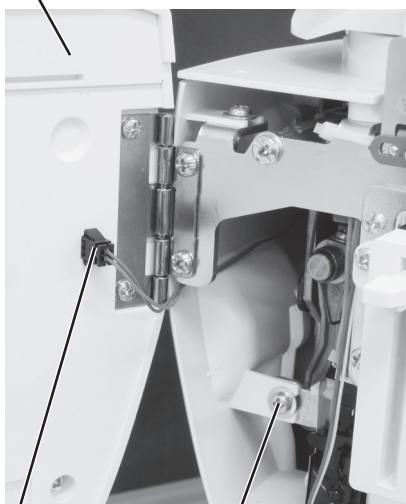

Connector

Setscrew A

Carrying handle



Rear cover

To remove:

1. Remove the top cover, base plate, base cover, bed cover and free arm cover (refer to pages 1, 3 to 5).
2. Open the face cover.
3. Loosen the setscrew A.

4. Raise the carrying handle.

Setscrew B

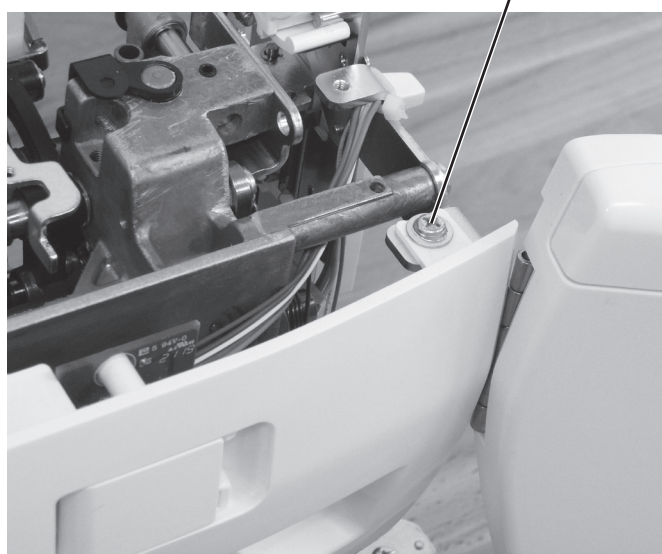

5. Loosen the setscrew B.
Close the face cover.

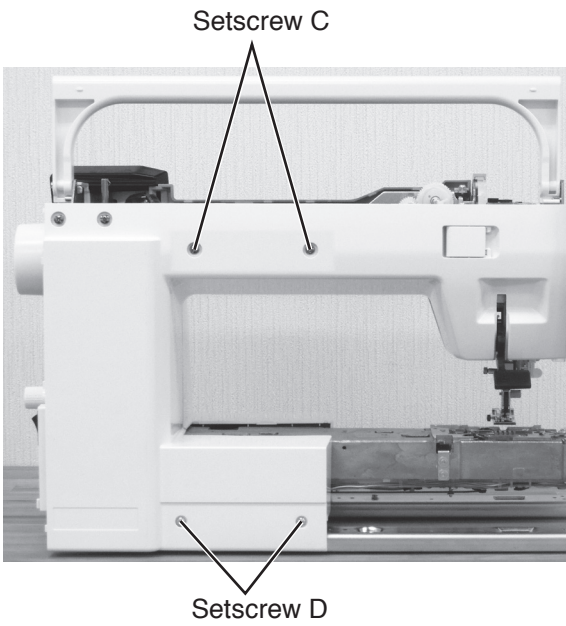

6. Remove the setscrews C (2 pcs.) and setscrews D (2 pcs.).

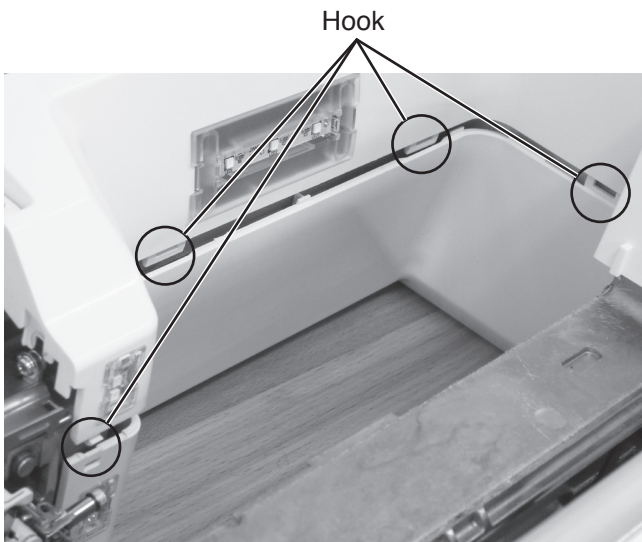

7. Unlock the rear cover hooks from the front cover.

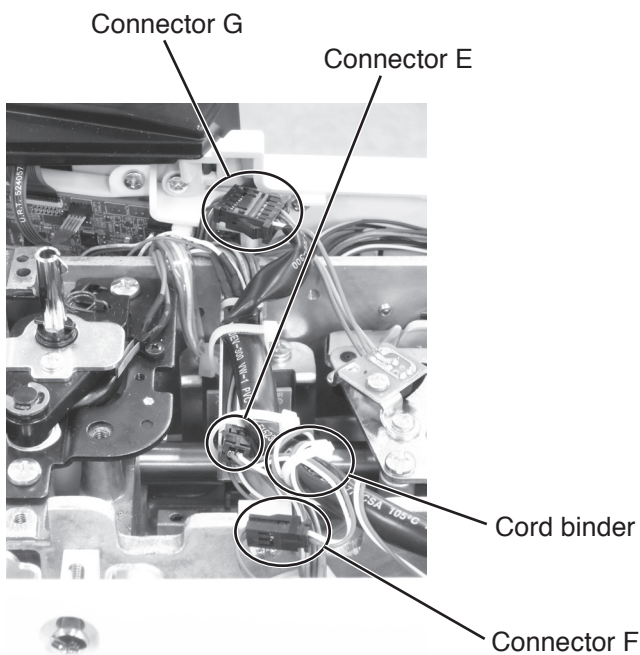

8. Disconnect the connector E, connector F and connector G from the sockets. Cut and remove the cord binder as necessary. Remove the rear cover.

To attach:

9. Follow the above procedure in reverse.

Replacing Electronic Components

Before replacing the printed circuit board A, copy the data in the board to a USB flash drive.

* Check the clear set mode (refer to page 45).

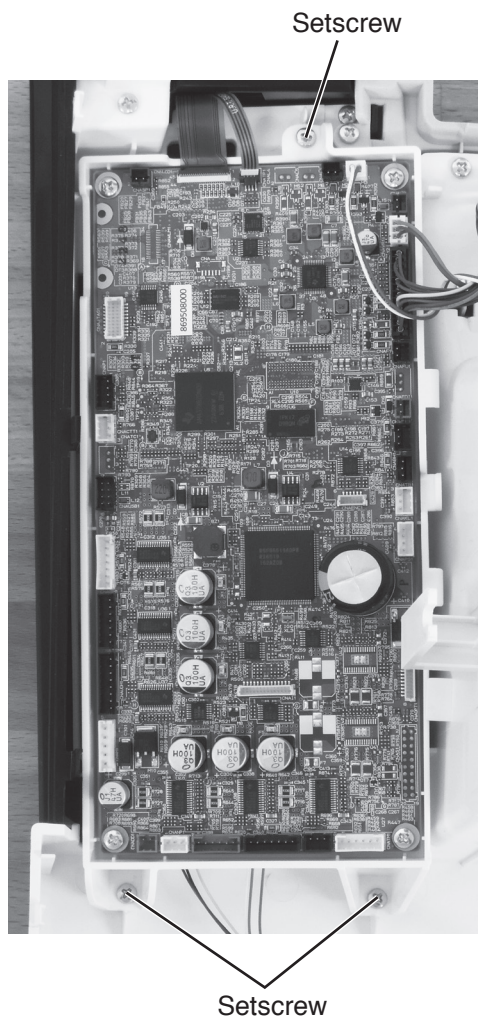

Printed circuit board A case

NOTE:

Do not disconnect the connectors by pulling on cord.

To disconnect the connectors, grasp the connector, not the cord.

To remove:

1. Remove the front cover (refer to pages 6 and 7).
2. Grasp the connector directly with your fingers and pull.
Do not pull the lead wire, as this may damage the contact sleeve inside the connector.
Remove the setscrews (3 pcs.) and printed circuit board A case.

To attach:

3. Follow the above procedure in reverse.
Be sure that the connector post on the printed circuit board to which it is connected.
Position the connector correctly, then push it straight down until it locks in place.

Replacing Electronic Components

Before replacing the printed circuit board A, copy the data in the board to a USB flash drive.
 * Check the clear set mode (refer to page 45).

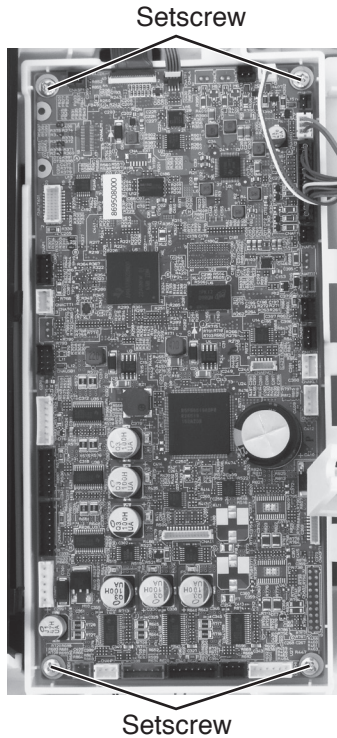

Printed circuit board A

NOTE:

Do not disconnect the connectors by pulling on cord.
 To disconnect the connectors, grasp the connector, not the cord.

To remove:

1. Remove the front cover (refer to pages 6 and 7).
2. Remove the setscrews (4 pcs.) and disconnect all the connectors from the printed circuit board A.
 Remove the printed circuit board A.

To attach:

3. Follow the above procedure in reverse.
 Be sure that the connector post on the printed circuit board to which it is connected.
 Position the connector correctly, then push it straight down until it locks in place.

Printed circuit board A connection

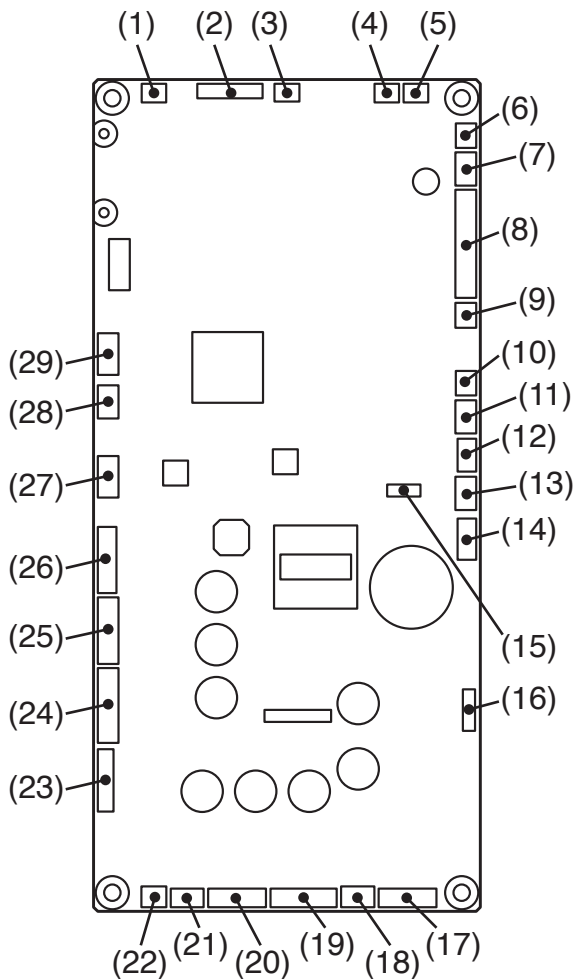

- (1) Bobbin winder switch
- (2) LCD (Flexible)
- (3) Touch panel (Flexible)
- (4) Printed circuit board L1 (black)
- (5) Printed circuit board L2 (white)
- (6) Printed circuit board L3 (red)
- (7) Slide volume
- (8) Printed circuit board F
- (9) Presser foot lifter switch
- (10) ErP switch (Auto-off timer switch)
- (11) BH sensor
- (12) Upper thread sensor
- (13) Knee lifter sensor
- (14) Power switch
- (15) Rotary encoder
- (16) Stitch regulator
- (17) Thread cutter motor
- (18) Remaining bobbin thread detecting sensor
- (19) Feed motor
- (20) Remaining bobbin thread detecting motor
- (21) Needle plate sensor
- (22) Drop feed detecting sensor (brown)
- (23) DC motor
- (24) Presser foot lifter motor
- (25) Thread tension motor
- (26) Zigzag motor
- (27) USB
- (28) Foot control & Thread cutter switch jack
- (29) Phase sensor

Replacing Electronic Components

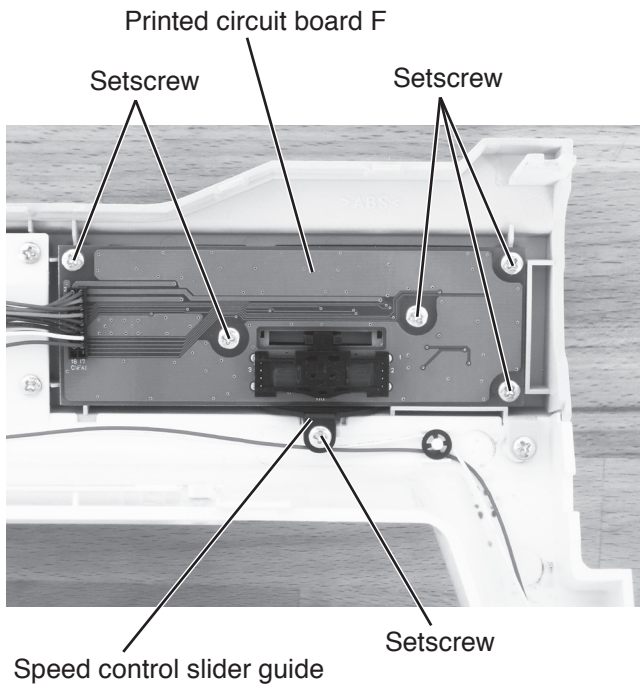

Printed circuit board F

To remove:

1. Remove the front cover (refer to pages 6 and 7).
2. Disconnect the connectors from the printed circuit board A (refer to page 11).
3. Remove the setscrew (6 pcs.).
4. Remove the printed circuit board F and remove the speed control slider guide.

To attach:

5. Follow the above procedure in reverse.

Replacing Electronic Components

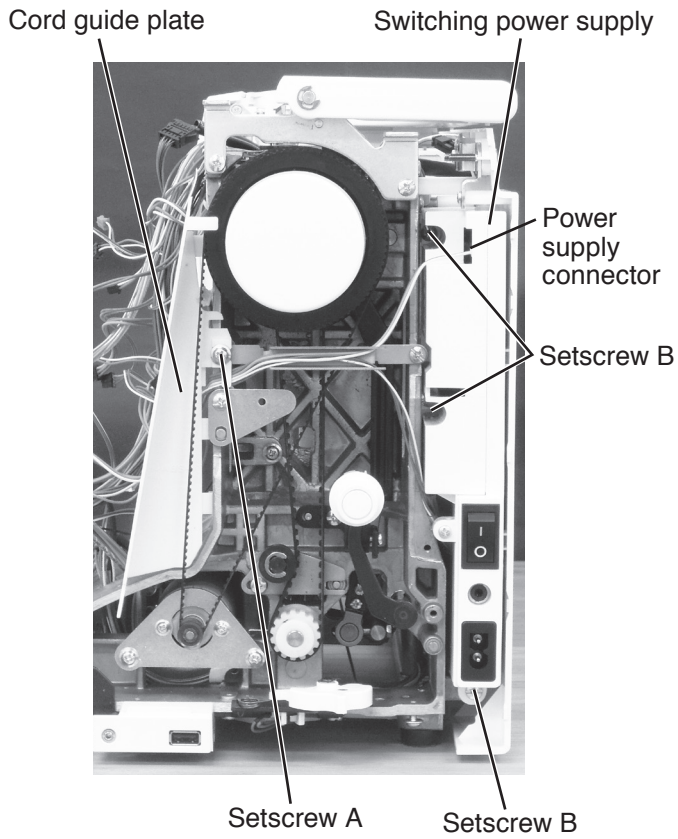

Switching power supply

To remove:

1. Remove the top cover, belt cover and front cover (refer to pages 1, 2, 6 and 7).
2. Loosen the setscrew A and remove the cord guide plate.

3. Disconnect the power supply connector from the switching power supply unit.

4. Remove the setscrews B (3 pcs.) and the switching power supply.

To attach:

5. Follow the above procedure in reverse.

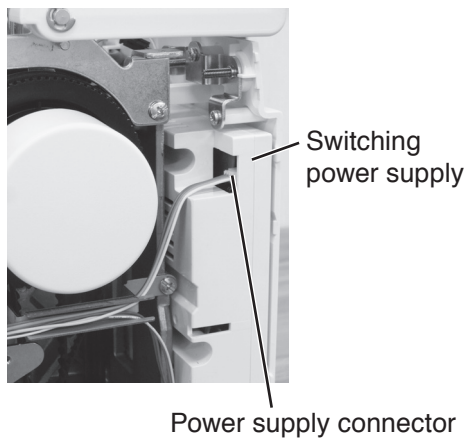

Replacing Electronic Components

DC motor

To remove:

1. Remove the top cover, belt cover and front cover (refer to pages 1, 2, 6 and 7).
2. Remove the setscrews (2 pcs.) and the motor belt. Remove the DC motor.

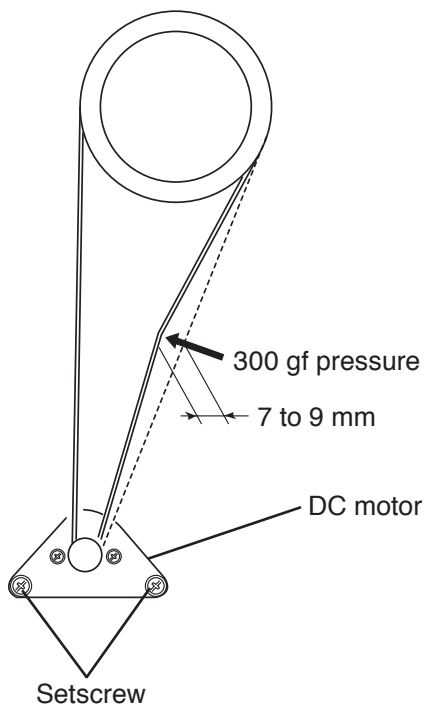
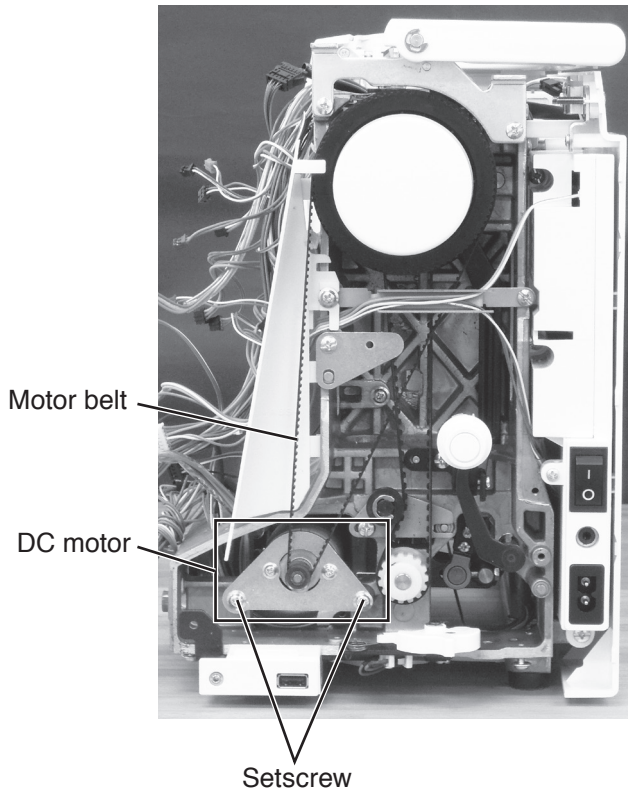

To attach:

3. Attach the DC motor. Tighten the setscrews (2 pcs.) temporarily.
4. Adjust the motor belt deflection to about 7 to 9 mm by pressing the middle of the motor belt with your finger with approximately 300 grams-force of pressure.
5. Tighten the setscrews (2 pcs.) securely.
6. Attach the front cover, belt cover and top cover.

Replacing Electronic Components



(View from the top)

Thread tension unit

To remove:

1. Remove the top cover, belt cover and the front cover (refer to pages 1, 2, 6 and 7).
2. Remove the setscrews A and B.

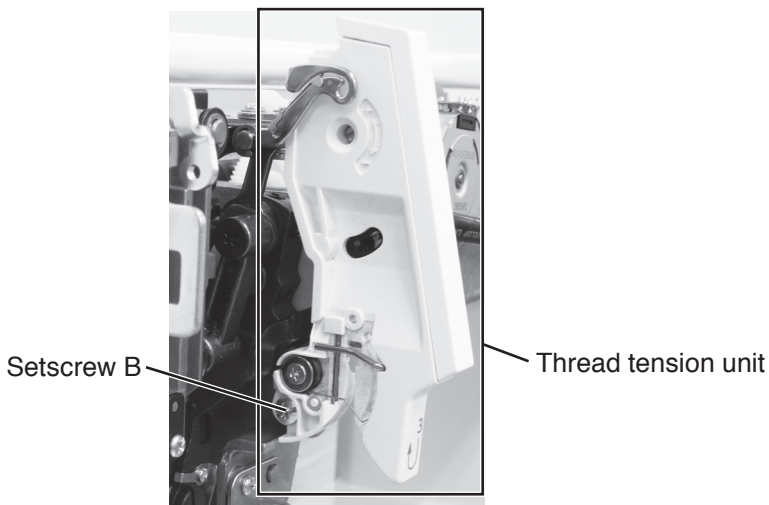

3. Cut the cord binder. Be careful not to cut the cords. Remove the setscrew C and cords from the nylon clip. Remove the nylon clip. Remove the thread tension unit.

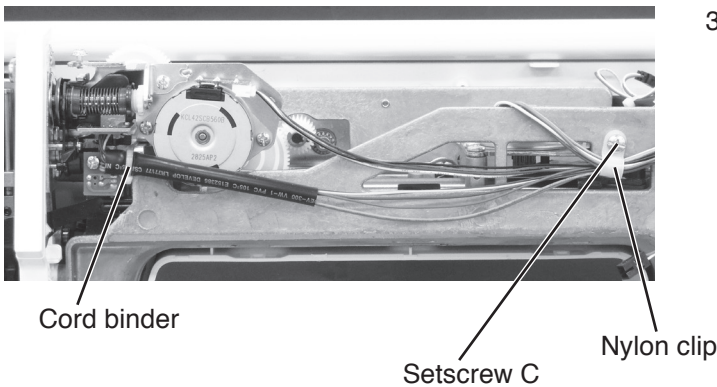

To attach:

4. Follow the above procedure in reverse.
5. Check the upper thread tension (refer to page 24).

Mechanical Adjustment

Feed dog height

When the foot presser foot pressure value is at “6” and the presser foot is lowered, the highest position of the feed dog should be 0.90 to 1.00 mm from the surface of the needle plate.

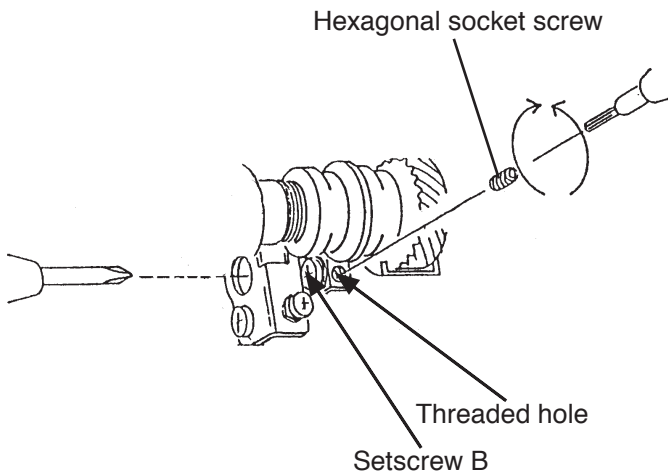
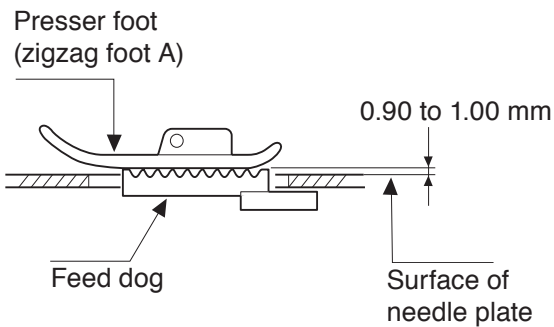
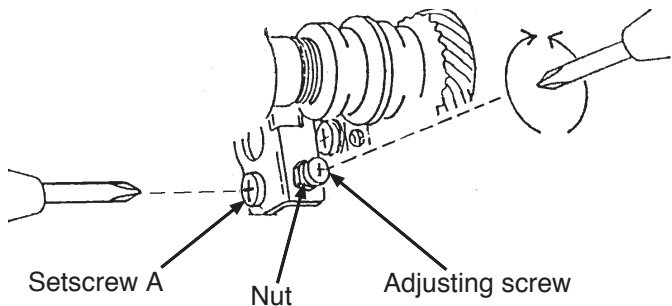
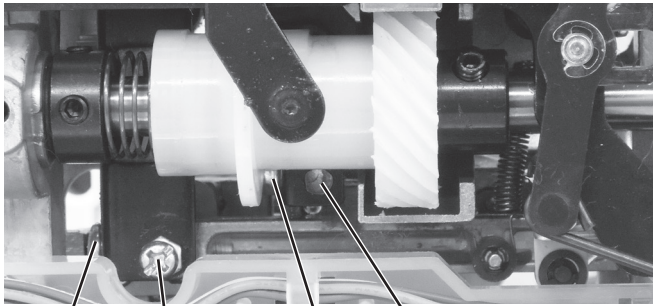

Adjustment 1:

1. Attach the zigzag foot A.
Remove the base cover and bed cover (refer to page 3).
2. Turn the power switch ON.
Adjust the stitch length to the maximum (5.0).
3. Press the presser foot lifter button to lower the presser foot.
4. Turn the handwheel toward you to raise the feed dog to its highest position.
5. Loosen the setscrew A.
6. Loosen the nut with a socket wrench.
Turn the adjusting screw and adjust the feed dog height to 0.90 to 1.00 mm.
7. Tighten the nut and setscrew A.
8. Turn the handwheel and check that the feed dog teeth are in parallel with the surface of the needle plate. If not, follow the adjustment procedure below.

Adjustment 2:

If the feed dog is not parallel to the surface of the needle plate at its highest position, make the adjustment as follows:

* For this adjustment, a hexagonal socket screw 4x6, part No. 000111108 is required.

1. Insert a hexagonal socket screw, part no. 000111108 into the threaded hole until it stops. (use an Allen wrench of 2 mm width across flats).
2. Turn the setscrew B (left hand screw) clockwise to loosen it.
3. Turn the hexagonal socket screw I until the feed dog is parallel with the surface of the needle plate.
4. Tighten the setscrew B by turning it counterclockwise.
5. Remove the hexagonal socket screw.
6. Attach the bed cover and base cover.

Mechanical Adjustment

Needle drop position

When the straight stitch  is selected, the needle should be positioned in the center of the needle plate hole.

When the needle drop position is set at "0.0" and "9.0", the clearance between the side of the needle and the needle hole should be 0.2 mm or more.

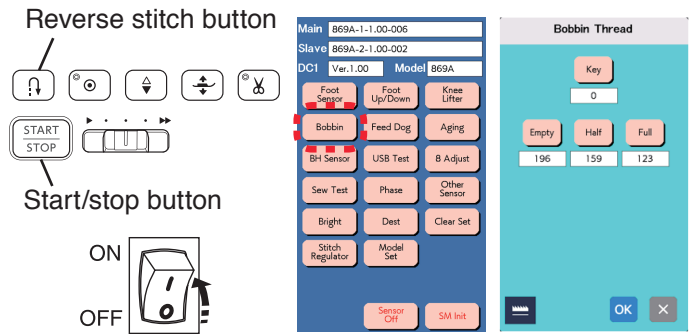

To adjust:

1. Attach the #14 needle.
Turn the power switch ON while pressing the start/stop button and the reverse button to enter the factory setting mode.
The LCD shows the factory setting mode.
2. Press the "Bobbin" key.
* When you press "Bobbin" key in the factory setting mode, the maximum stitch width will be set at 9.0 automatically.
3. If the clearance is less than 0.2 mm, adjust it as follows.
Loosen the hexagonal socket screw (use an Allen wrench of 2 mm width across flats).

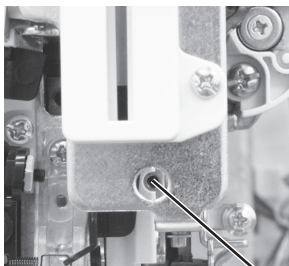
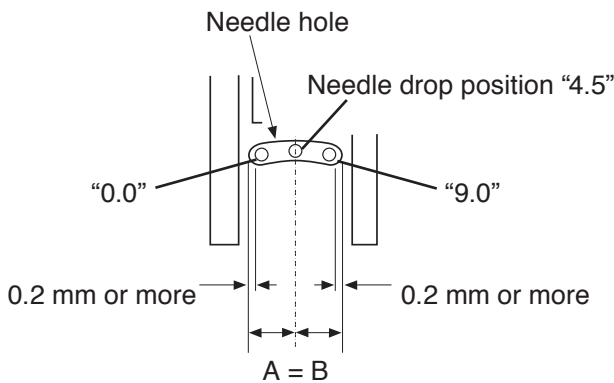

Hexagonal socket screw

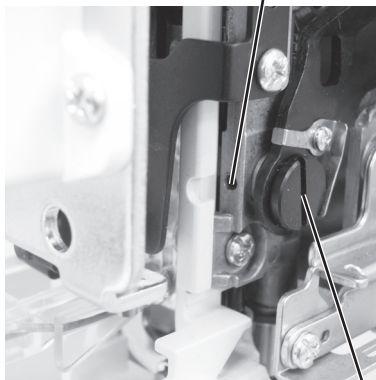

Eccentric pin

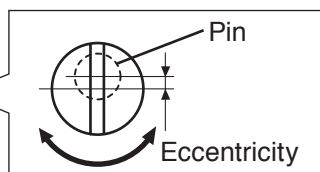

4. Turn the eccentric pin to get 0.2 mm or more clearance.
The direction of eccentric pin should be as shown. Tighten the hexagonal socket screw.
Attach the straight needle plate and check if the needle drops in the center of the needle hole.
Check the hook timing and the needle bar height after this adjustment (refer to pages 20 and 21).

Mechanical Adjustment

Clearance between needle and tip of the rotary hook (method 1)

The clearance between the needle and the point of hook should be -0.10 to $+0.05$ mm.

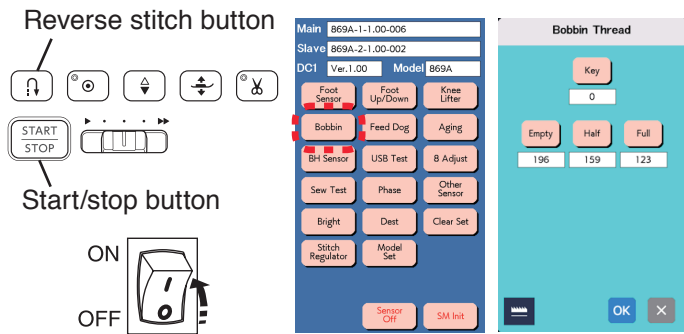

1. Remove the top cover (refer to page 1).
2. Remove the presser foot, the needle plate and the bobbin holder.
3. Attach the test pin.
4. Turn the power switch ON while pressing the start/stop button and the reverse stitch button. The LCD shows the factory setting mode. Press the “Bobbin” key. The zigzag width will be set at its maximum value.
5. Turn the handwheel toward you until the tip of the hook comes behind the test pin.

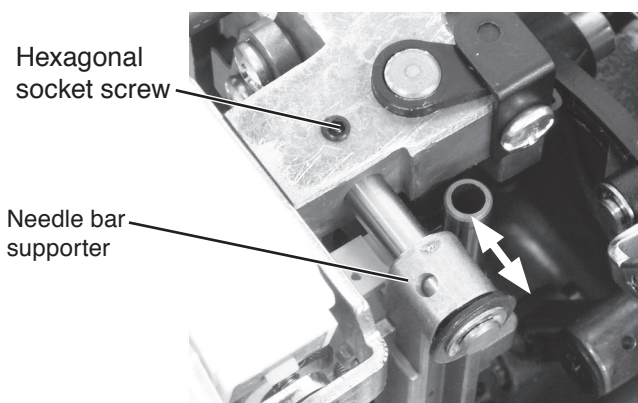
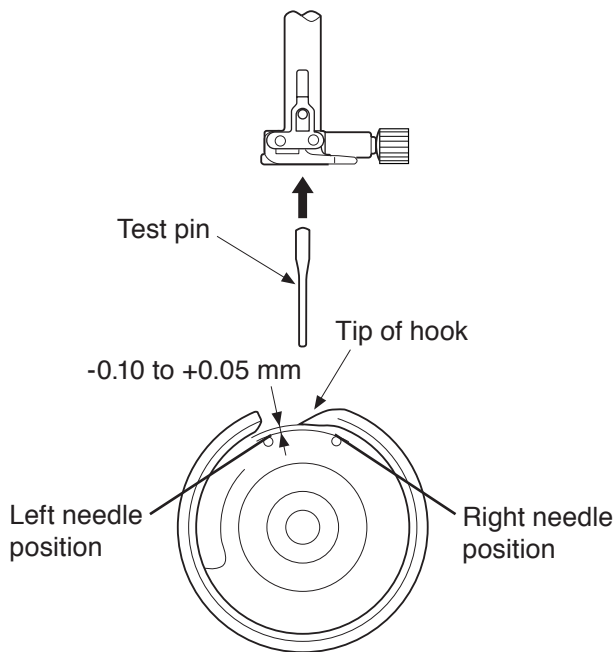

6. Loosen the hexagonal socket screw (use an Allen wrench of 2 mm width across flats) and move the needle bar supporter in the direction of the arrow so the test pin just touch the tip of the hook. Tighten the hexagonal socket screw.

Clearances A and B must be even

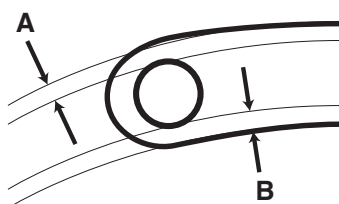

7. Attach the bobbin holder and the needle plate. Check the needle drop position. The needle drops in the center of the needle plate hole as shown.

If the clearances A and B are not even, adjust the needle drop position first and then adjust the clearance between the needle and the tip of the hook by the method (2) on the next page.

Mechanical Adjustment

Clearance between needle and tip of the rotary hook (method 2)

The clearance between the needle and the point of hook should be -0.10 to $+0.05$ mm.

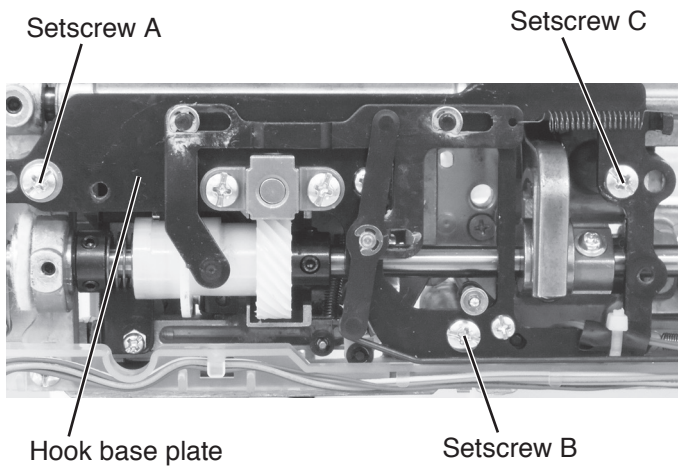

1. Remove the bed cover (refer to page 3).
 2. Loosen the setscrews A, B and C. Tighten the setscrew C lightly.
 3. Turn the handwheel toward you until the tip of the hook comes behind the test pin. Adjust the clearance between the needle and the tip of the rotary hook, by moving the hook base plate up or down, so the test pin just touch the tip of the hook.
 4. Tighten the setscrews A, B and C.
 5. Check the backlash between the lower shaft gear and the hook drive gear. If the backlash is too great or the engagement of the gears is too tight, adjust the backlash (refer to page 22).
- * Check the hook adjustment and needle bar height after this adjustment (refer to pages 20 and 21).

Mechanical Adjustment

Hook timing

The amount of ascending travel of the needle bar from its lowest position to the position (needle drop position 0.0) where the tip of the rotary hook exactly meets the right side of the needle should be 3.70 to 4.00 mm.

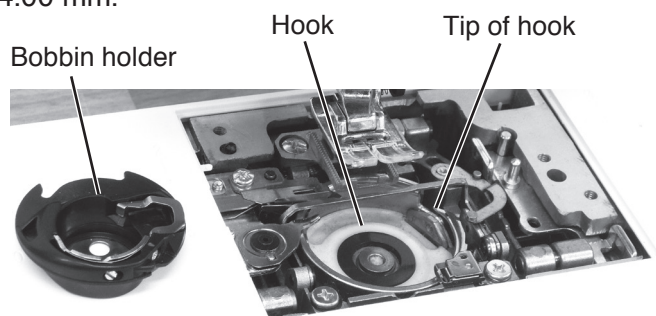

(Needle drop position "0.0")

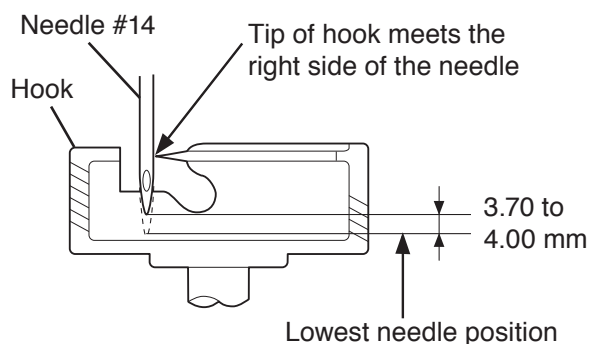

To adjust:

1. Remove the base cover and bed cover (refer to page 3).
2. Attach the needle #14.
3. Turn the power switch on and select straight stitch (). Set the needle drop position at "0.0".
* Do not turn the switch OFF.
4. Remove the presser foot, the needle plate and the bobbin holder.
5. Turn the handwheel toward you to lower the needle at its lowest position.

6. Loosen the hexagonal socket screws (2 pcs.) (use an Allen wrench of 2 mm width across flats).
7. Turn the handwheel toward you to raise the needle bar by 3.70 to 4.00 mm from its lowest position.
8. Turn the lower shaft gear until the tip of rotary hook meets with the right side of the needle. Tighten the hexagonal socket screws (2 pcs.).
* Check the needle bar height after this adjustment (refer to page 21).
9. Attach the bed cover and base cover.

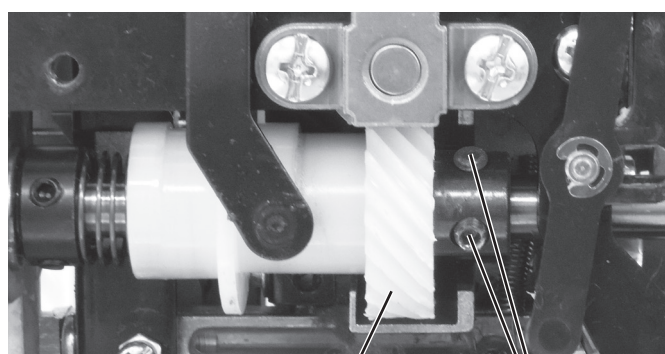

Lower shaft gear

Hexagonal socket screw

Mechanical Adjustment

Needle bar height

The distance between the upper edge of the needle eye and the hook race should be in the range of 1.6 to 2.0 mm when the tip of the hook meets right side of the needle in the needle drop position "0.0" as the needle ascends from its lowest position.

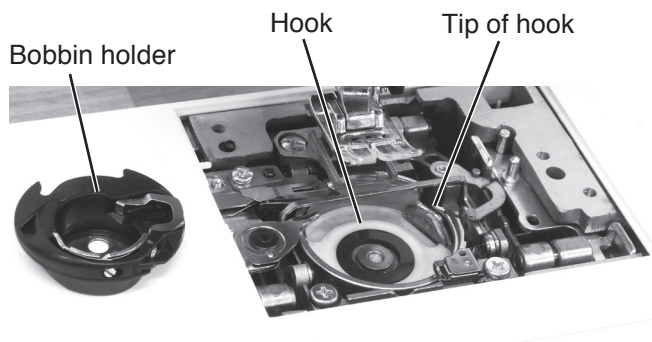

1. Attach the needle #14.
2. Turn the power switch ON.
Turn the power switch on and select straight stitch (↓).
Set the needle drop position at "0.0".

* Do not turn the switch OFF.
3. Remove the presser foot, the needle plate and the bobbin holder.

* Cover the needle plate with the fabric to prevent damaging the needle plate when removing.

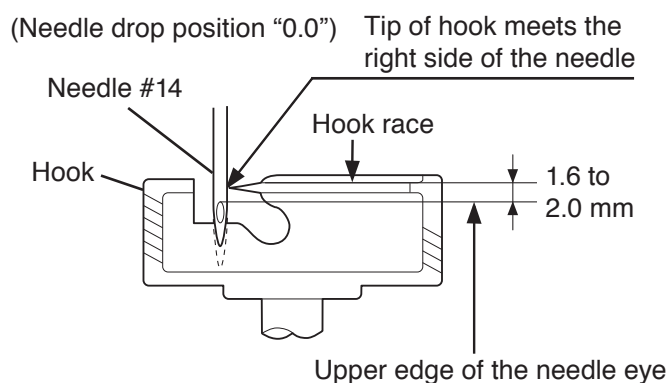

4. Turn the handwheel toward you until the tip of hook meets the right side of the needle.

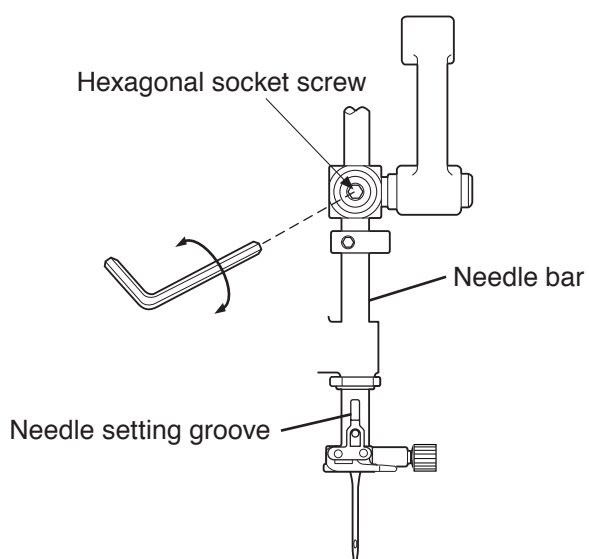

5. Loosen the hexagonal socket screw (use an Allen wrench of 2 mm width across flats).
6. Move the needle bar to adjust the needle bar height. Tighten the hexagonal socket screw. Be careful not to turn the needle bar.
7. Attach the bobbin holder and needle plate.

Mechanical Adjustment

Backlash between hook drive gear and lower shaft gear

The rotary play of the hook should be 0.8 mm or less when the tip of rotary hook is within the width of feed dog.

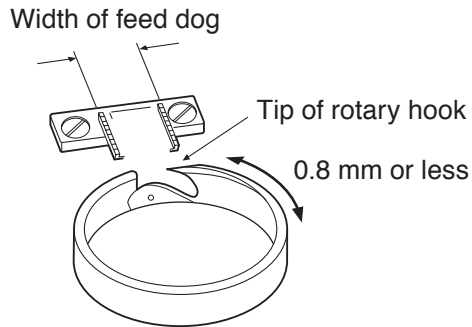

1. Remove the base cover and bed cover (refer to page 3).
2. Remove the presser foot, the needle plate and the bobbin holder.
 - * Cover the needle plate with the fabric to prevent damaging the needle plate when removing.
3. Turn the handwheel toward you so the tip of the rotary hook is within the width of feed dog as shown. Check the rotary play of the hook.
4. If the backlash is too much or too little, loosen the hexagonal socket screw C and D and following the adjustment procedure.
 - * Turn the lower shaft bushings (front side and belt cover side) in the same direction simultaneously and evenly.
 - * If the backlash is too much, turn the lower shaft bushings (front side and belt cover side) in direction A.
 - * If the backlash is too little, turn the lower shaft bushings (front side and belt cover side) in direction B.
5. Tighten the hexagonal socket screws C and D.
6. Attach the base cover, bed cover, presser foot, needle plate and bobbin holder.

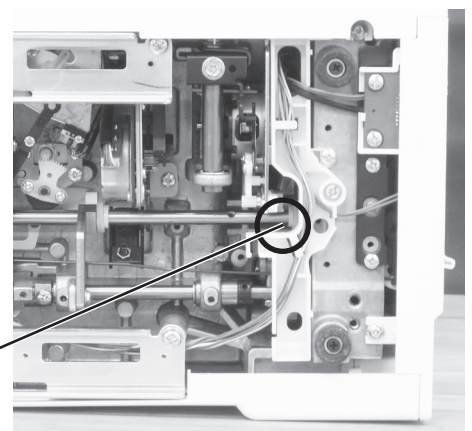
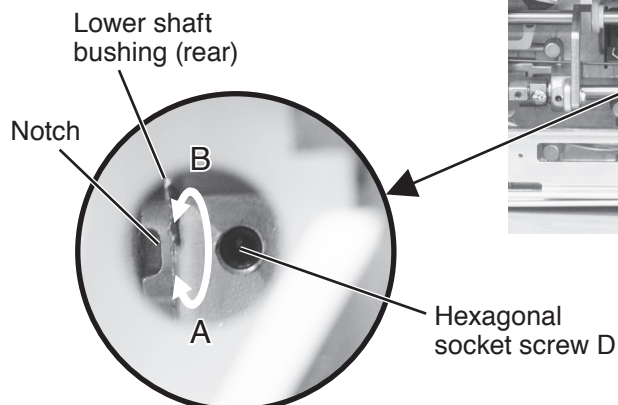
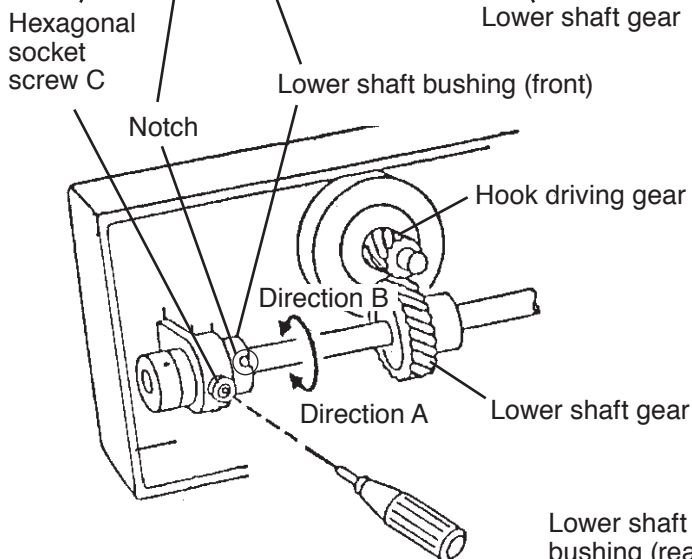
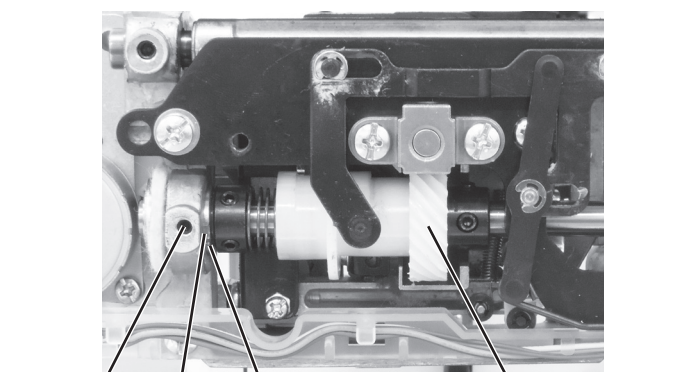

Mechanical Adjustment

Upper shaft shield plate position

When the machine is set for zigzag stitch, the needle should start to swing 7.2 to 8.2 mm above the surface of the needle plate.

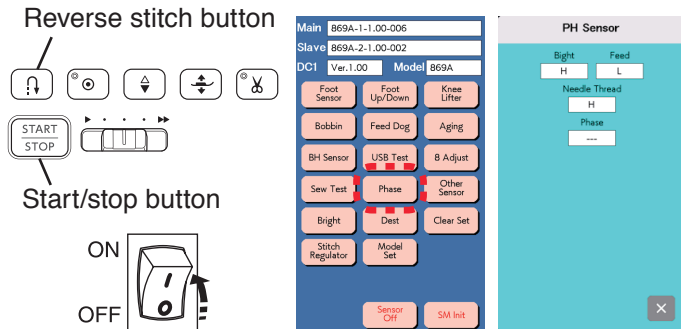

To check:

1. Attach the needle #14.
Turn the power switch ON while pressing the start/stop button and the reverse stitch button. The LCD shows the factory setting mode. Press the "Phase" key.
2. Turn the handwheel toward you slowly to bring the needle up from its lowest. The indication below "Bight" changes from L to H.
3. The needle height should be 7.2 to 8.2 mm above from the surface of the needle plate. If not, adjust the upper shaft shield position.

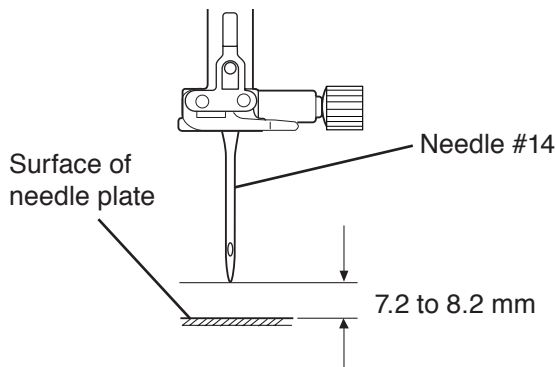

To adjust:

1. Remove the top cover (refer to page 1).
2. Turn the handwheel toward you and raise the needle 7.7 mm above the surface of the needle plate.
3. Loosen the setscrew of the upper shaft shield plate. Turn the upper shaft shield plate until the indication changes from L to H. Tighten the setscrew.

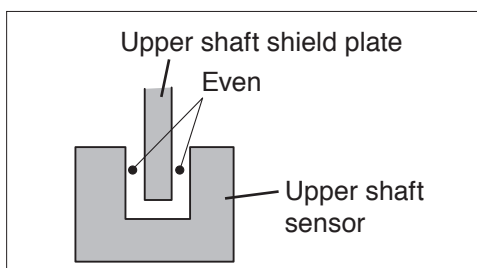
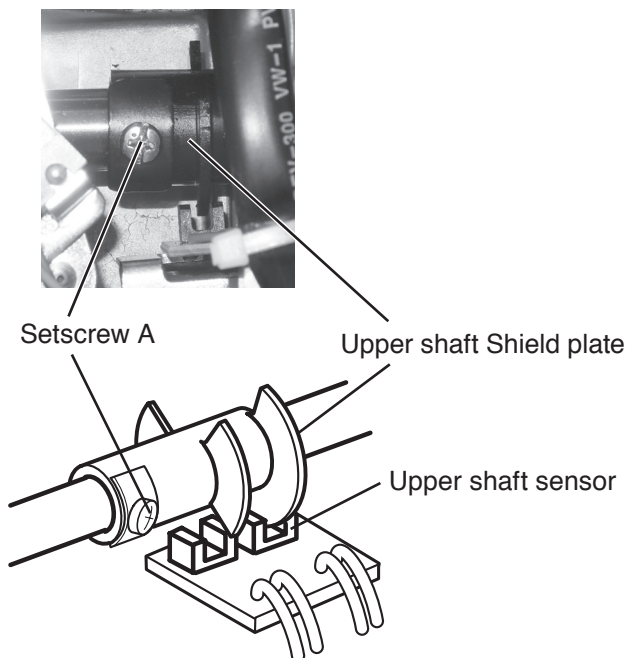

The position of the upper shaft shield plate should be in the center of the upper shaft sensor.

Mechanical Adjustment

Upper thread tension

The standard upper thread tension should be 59 to 67 grams when the machine is set for pattern No.1 (U1) and the thread tension is set at “3.4”, measured with a #50 polyester thread being pulled at approximately 110 mm/sec. in the direction of arrow.

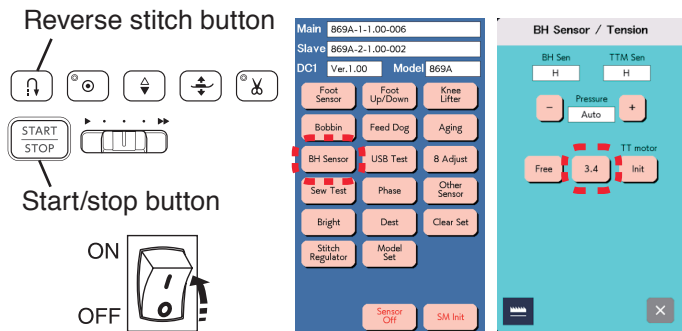

1. Turn the power switch ON while pressing the start/stop button and the reverse stitch button. The LCD shows the factory setting mode. Press the “BH Sensor” key.

2. Thread #50 polyester thread to the machine.
3. Set the thread tension “3.4” by pressing “3.4” key.
4. Open the face cover.
 - (A) If the thread tension is less than 59 gf, turn the adjusting screw in the direction of “+”.
 - (B) If the thread tension is more than 67 gf, turn the adjusting screw in the direction of “-”.

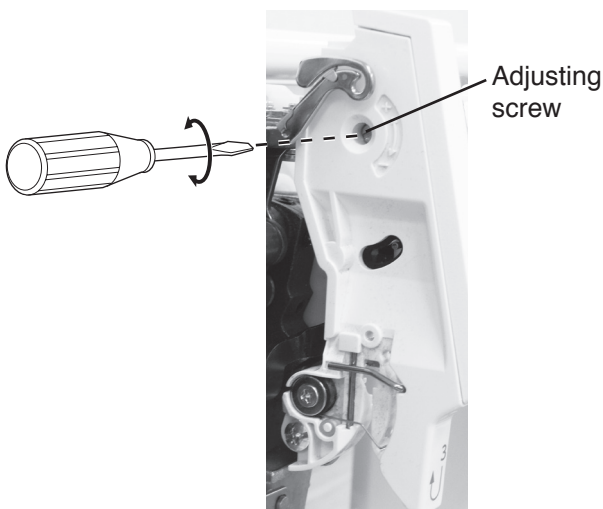

Pulling direction: (pulling speed 110 mm/sec.)

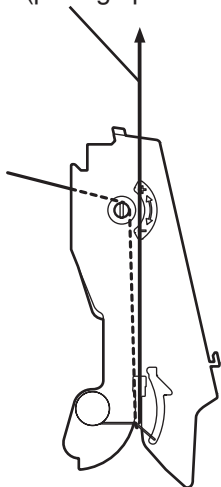

Mechanical Adjustment

Tension release mechanism

When the presser foot lifter is raised, the tension release mechanism should work correctly.

Convex is NOT set at tension release claw

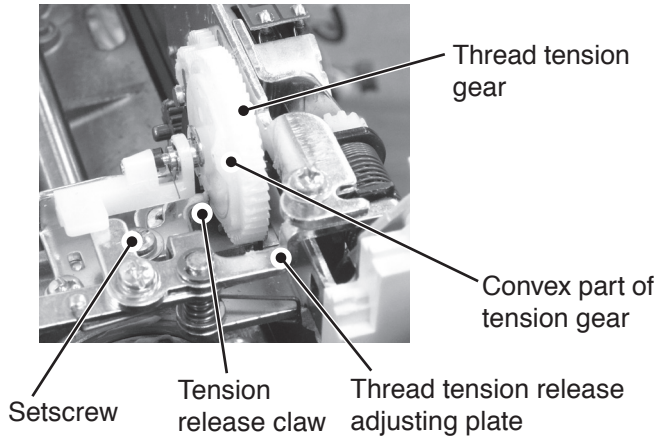

1. Remove the belt cover and top cover (refer to pages 1 and 2).
2. Remove the front cover (refer to pages 6 and 7).
3. Turn the power switch off.
Turn the thread tension gear until the convex part of tension gear is NOT set at the tension release claw.
4. Loosen the setscrew.
5. Adjust the clearance between the tension release adjusting plate and the tension disc supporter to 0.2 mm to 0.8 mm.
6. Turn the thread tension gear until the convex part of tension gear is set at the tension release claw.
Be sure that the tension release adjusting plate touches the tension discs supporter and the tension discs opened slightly.

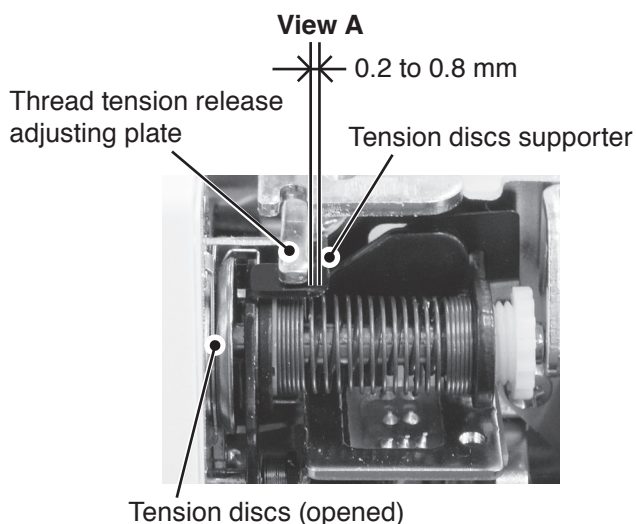
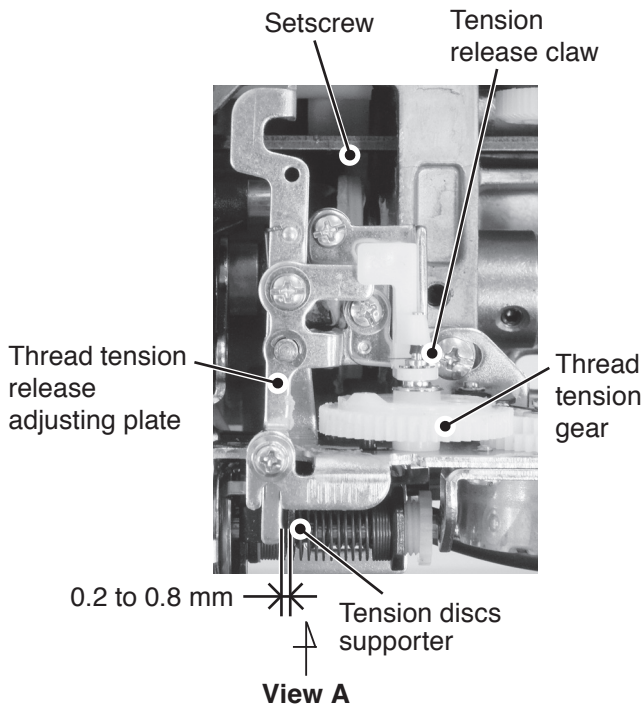

Convex is set at tension release claw

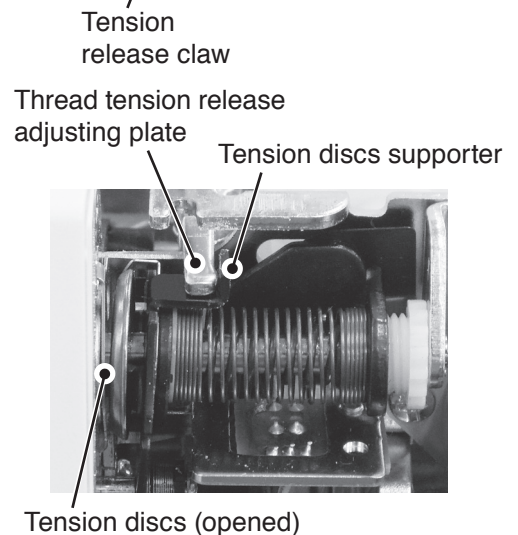
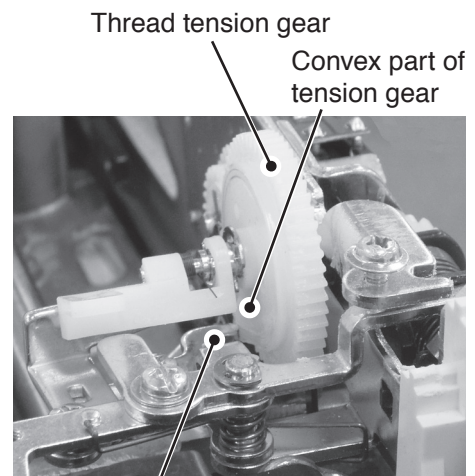

Mechanical Adjustment

Needle threader hook position

If the hook of the hook holder unit is damaged, replace or adjust the part as follows:

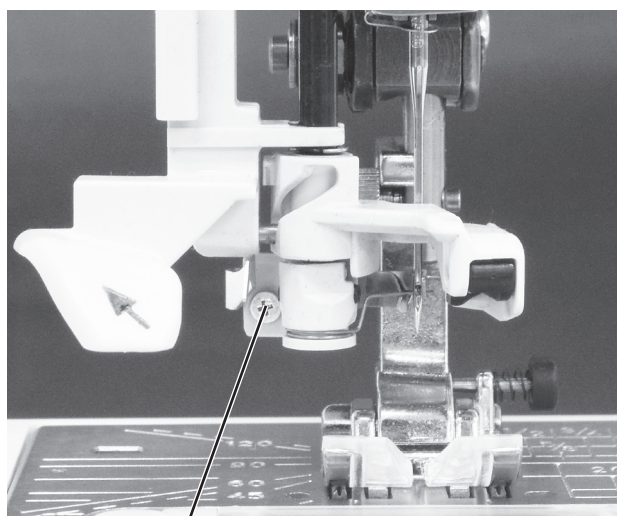

Setscrew

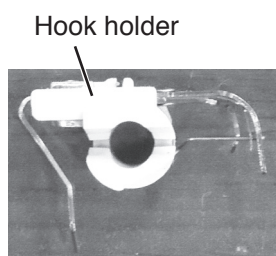

Hook holder

To replace:

1. Push down the needle threader lever and pull the hook holder unit down to remove it.
2. Replace the hook holder unit.

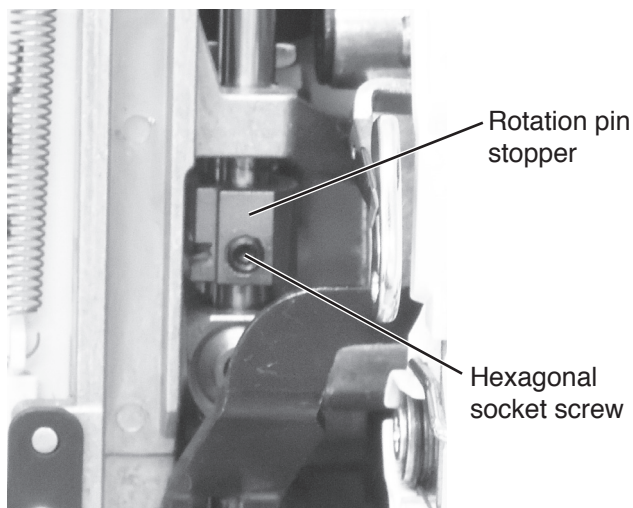

Rotation pin stopper

Hexagonal socket screw

To adjust:

1. Push down the threader lever and hold it just before the threader hook enters into the needle eye.
2. If the threader hook is not aligned vertically with the needle eye, loosen the hexagonal socket screw. Adjust the rotation pin stopper position so that the hook enters into the needle eye. Tighten the hexagonal socket screw.

If the threader hook is not aligned laterally with the needle eye, loosen the setscrew. Adjust the lateral position so that the hook enters into the needle eye. Tighten the setscrew.

- * Check the needle threader release amount for the wire of the hook holder after this adjustment (refer to page 27).

Mechanical Adjustment

Adjustment of the release amount for the wire of the hook holder

If the hook of the hook holder unit is damaged, replace or adjust the part as follows:

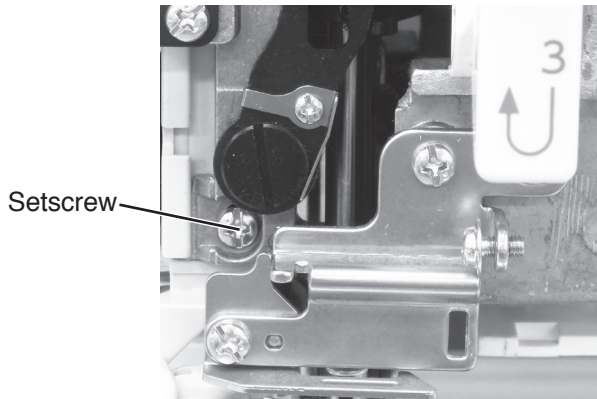

The clearance between the wire and the tip of the hook barb should be 0.5 mm or more. If the clearance is less than 0.5 mm, adjust it as follows.

1. Loosen the setscrew.
2. Adjust the thread release plate position up or down so that the clearance between the wire and the hook barb is 0.5 mm or more.

- * Check if the thread drops from the hook when the threading is finished.
- * The tip of the wire should not be on the left side of the curved part of the threader plate.

Thread release plate

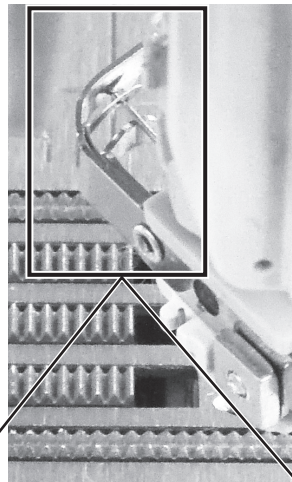
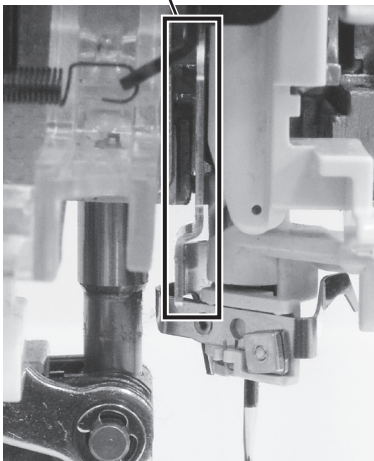

(View from the top)

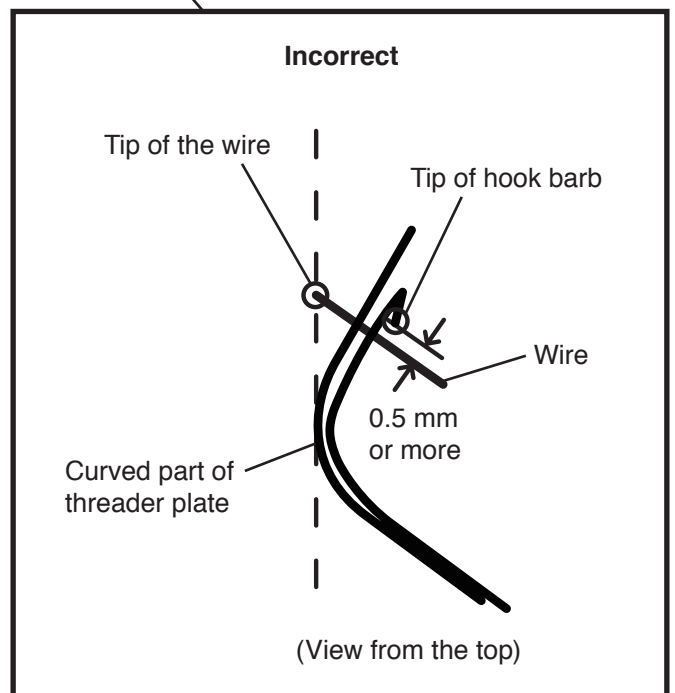
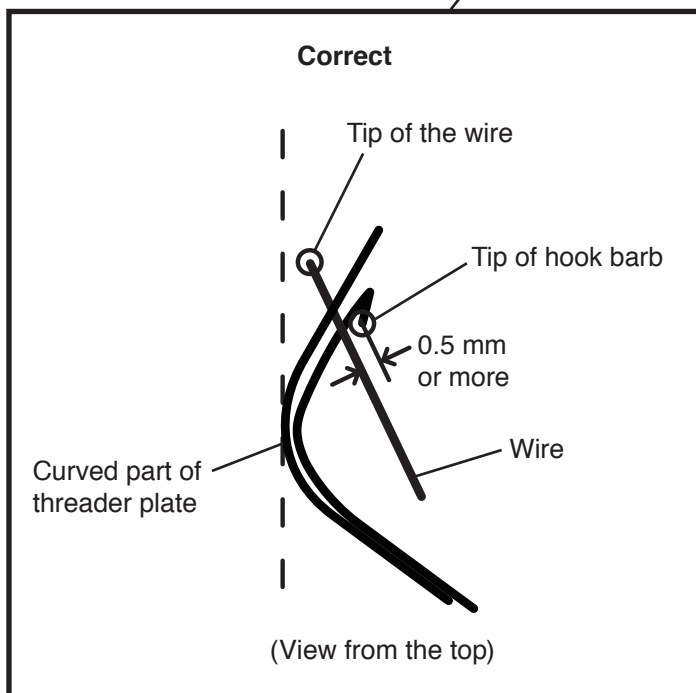

Mechanical Adjustment

Thread drawing lever

The standard height of the thread drawing lever from the surface of hook race should be in the range of 5.5 to 6.0 mm.

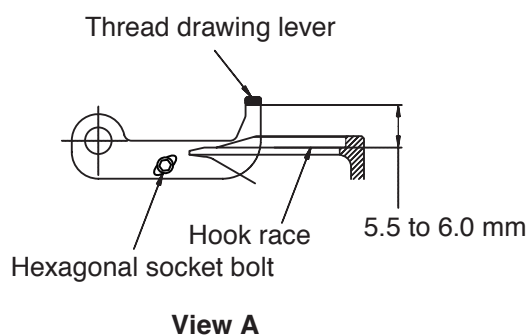
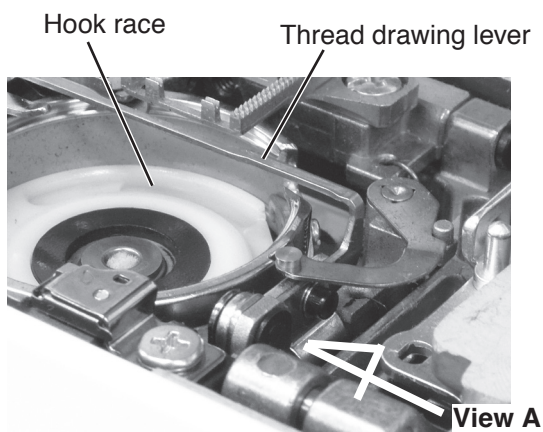

1. Remove the presser foot, the needle plate and the bobbin holder.

2. Loosen the hexagonal socket bolt (use an Allen key of 1.5 mm width across flats).
Adjust the distance between the lower part of thread drawing lever and the hook race to 5.5 to 6.0 mm by moving the thread drawing lever up or down.

3. Tighten the hexagonal socket bolt.

Mechanical Adjustment

Upper feed dog (1)

The clearance between the upper feed link shaft and upper feed lower shaft should be 2.5 mm when the upper feed adjusting dial is set to "0".

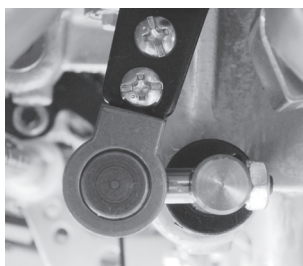
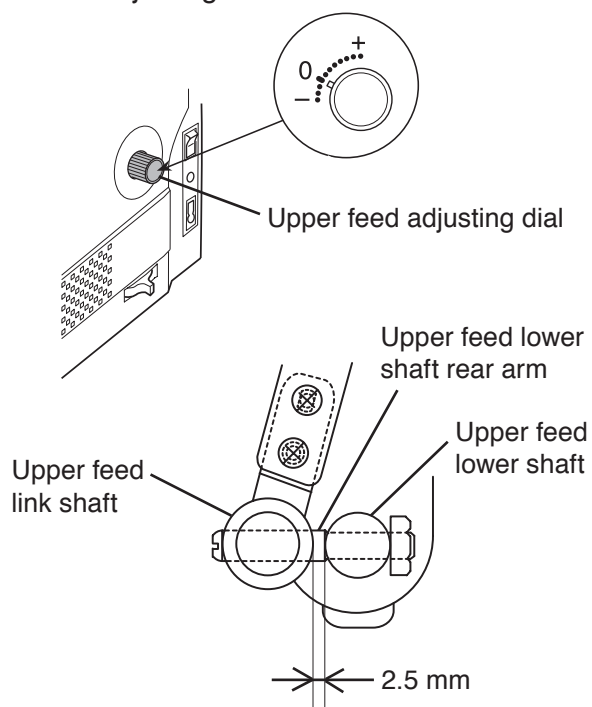

View from the belt cover

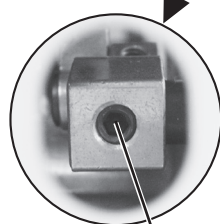
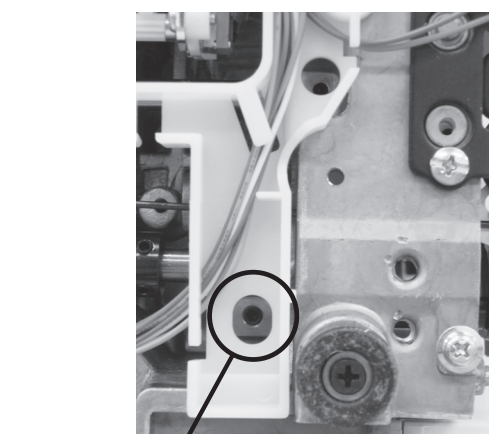

Hexagonal socket screw

To check:

1. Set the upper feed adjusting dial at "0".
Remove the belt cover and base plate (refer to pages 2 and 3).
2. Turn the power switch on and select straight stitch (\downarrow).
3. Lower the feed dog.
4. Press the needle up/down button twice to raise the needle, and the upper feed dog position will be initialized.
5. Check if the clearance between the upper feed link shaft and upper feed lower shaft is 2.5 mm.
If not, adjust it as follows.

To adjust:

1. Loosen the setscrew (use an Allen wrench of 2 mm width across flats) on the upper feed adjusting arm (1).
2. Adjust the clearance between the upper feed link shaft and upper feed lower shaft to 2.5 mm.

Mechanical Adjustment

Upper feed dog (2)

The clearance between the dual feed foot and upper feed dog should be 4 mm when the stitch length is set at "0".

* Check the upper feed dog (1) (refer to page 29) before this adjustment.

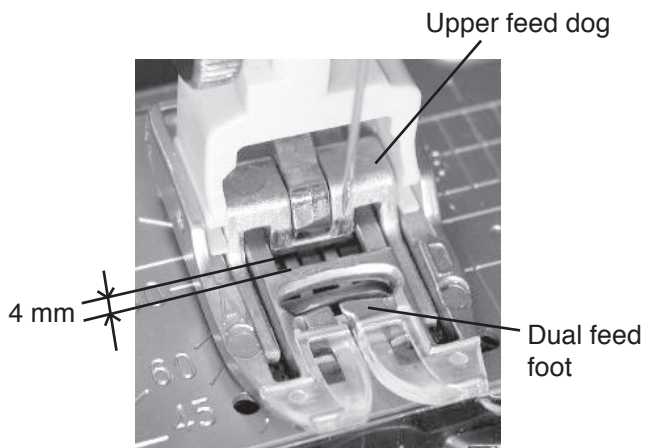
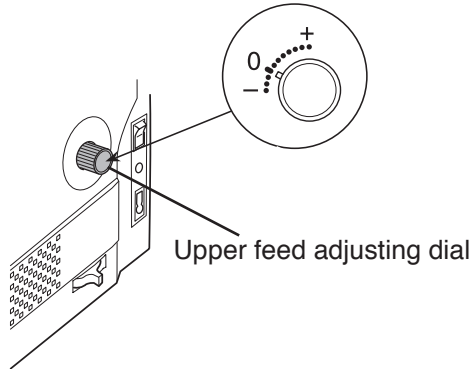

To check:

1. Attach the dual feed foot.
2. Turn the power switch on and select straight stitch ().
(Be sure that the machine is not locked.)
Press the adjusting key and set the stitch length at "0".
Turn the drop feed lever to drop the feed dog.
3. Turn the upper feed adjusting dial to set the dial at "0".
4. Press the needle up/down button twice to raise the needle.

* In order to initialize the feed dog position, press the needle up/down button twice and reset the needle position even though needle position is set at raised position.
5. Lower the presser foot.
Turn the power switch off.
6. The clearance between the dual feed foot and upper feed dog should be 4 mm. If not, follow the procedure below.

View from the right upper corner of the machine

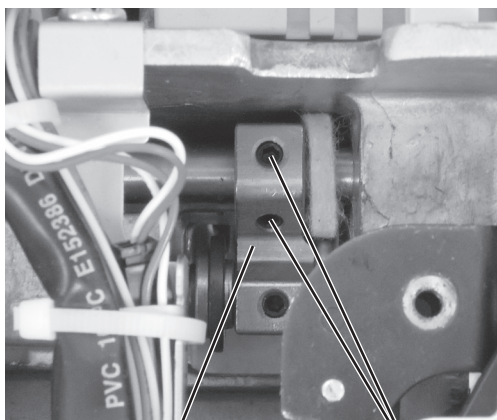

Upper feed upper shaft rear arm

Hexagonal socket screw

To adjust:

1. Remove the top cover (refer to page 1).
2. Loosen the hexagonal socket screws on upper feed rear arm (use an Allen wrench of 2 mm width across flats).
3. Insert the 4 mm spacer between the upper feed dog and dual feed foot to adjust the clearance.
Tighten the hexagonal socket screws.

Mechanical Adjustment

Upper feed dog (3)

The tip of the needle height should be 0 to 1 mm above the surface of the needle plate when the toe of the dual feed foot touch the needle plate.

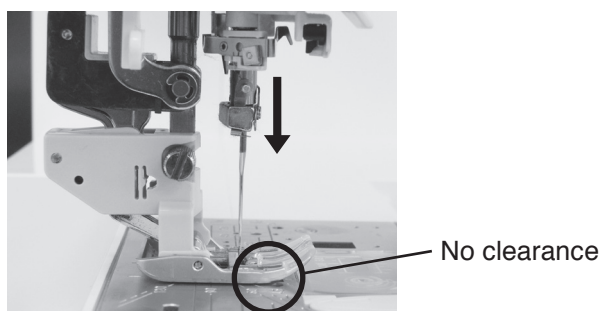
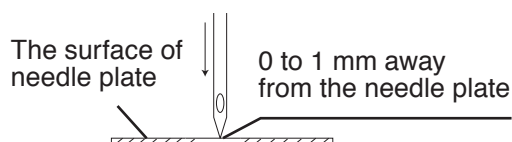
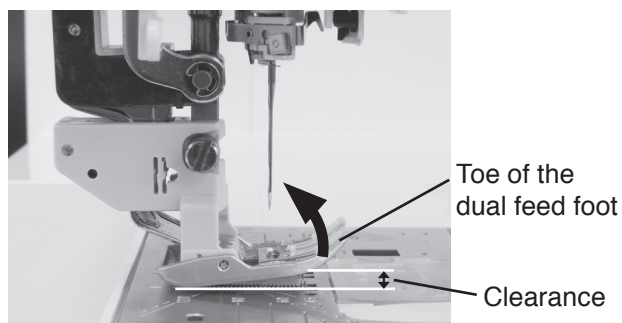
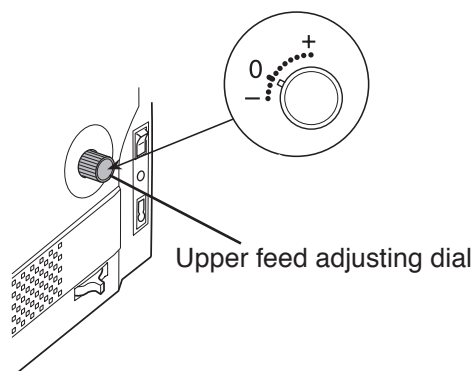

Hexagonal socket bolt

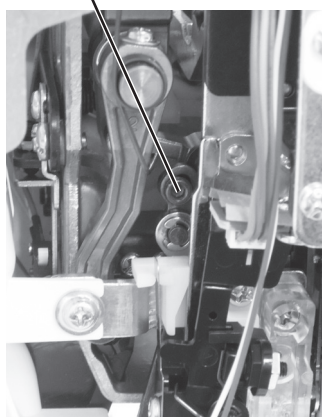

To check:

1. Set the upper feed adjusting dial at "0". Attach the dual feed foot.
2. Turn the power switch on and select straight stitch (⌄).
3. Lower the feed dog.
4. Press the needle up/down button twice to raise the needle, and the upper feed dog position will be initialized.
5. Press the presser foot lifter button to lower the presser foot. Turn the power switch off.
6. Raise the toe of the dual feed foot and leave it as it is.
7. Turn the handwheel toward you to lower the needle until the needle tip comes 1 mm or less above the needle plate.
8. The toe of the foot lands on the needle plate and there is no gap to allow the foot flapping. If not, adjust it as follows.

To adjust:

1. Open the face cover. Loosen the hexagonal socket bolt (use an Allen wrench with 2.5 mm width across flats).
2. Turn the handwheel toward you until the needle tip matches with the surface of the needle plate.
3. Tighten the hexagonal socket bolt while pressing the dual feed foot against the needle plate.
4. Check if there is no gap (see step 7 above).

Mechanical Adjustment

Buttonhole lever position

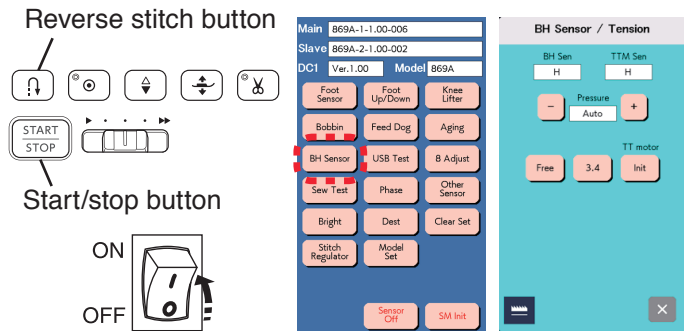

1. Turn the power switch ON while pressing the start/stop button and the reverse stitch button. The LCD shows the factory setting mode. Press the “BH Sensor” key.

Buttonhole lever guide Setscrew

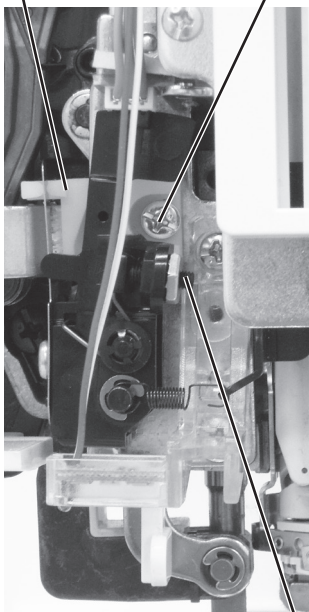

Hexagonal socket screw

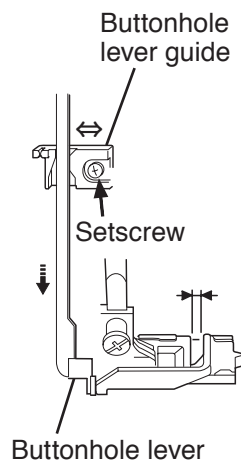

2. Open the face cover. Lower the buttonhole lever. Loosen the setscrew on the buttonhole lever guide. Move the buttonhole lever guide to the left to adjust the position. Tighten the setscrew when the indication below “BH Sen” changes from “H” to “L”.

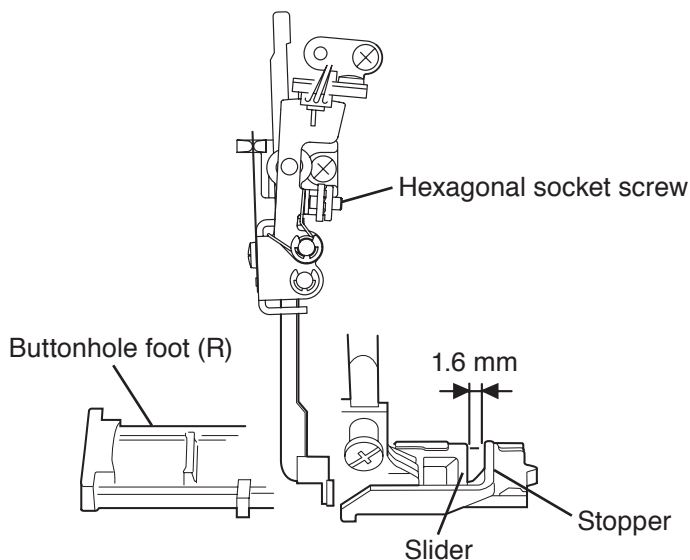

3. Attach the automatic buttonhole foot (R). Insert a 1.6 mm thick spacer between the stopper and slider of the foot.
4. Press the presser foot lifter button to lower the automatic buttonhole foot (R). Lower the buttonhole lever.
5. Turn the hexagonal socket screw counterclockwise (use an Allen wrench of 2 mm width across flats) until the indication below “BH Sen” shows “H”. Turn the setscrew slowly clockwise until the indication changes to “L”.

Mechanical Adjustment

Thread cutter

The distance between the end of thread cutter plate slit and the end of moving cutter should be in the range of 0.7 to 1.5 mm.

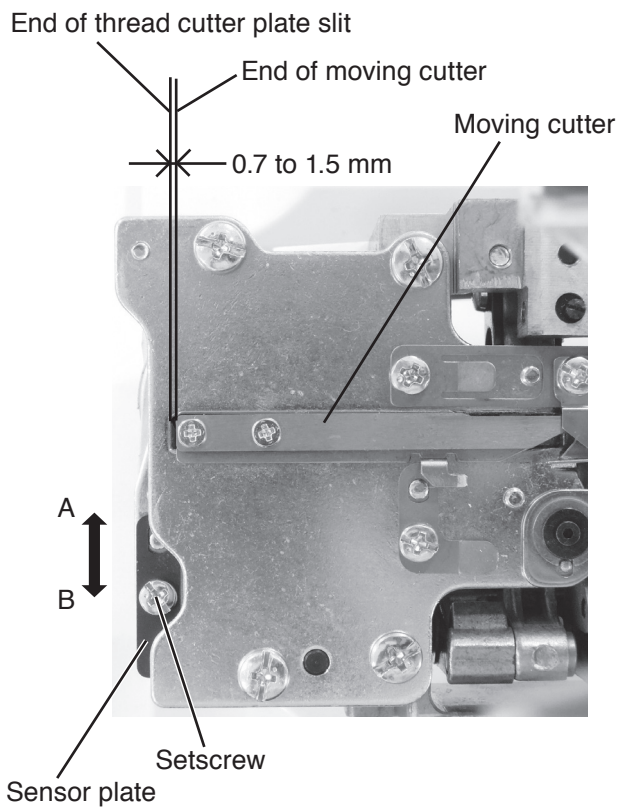
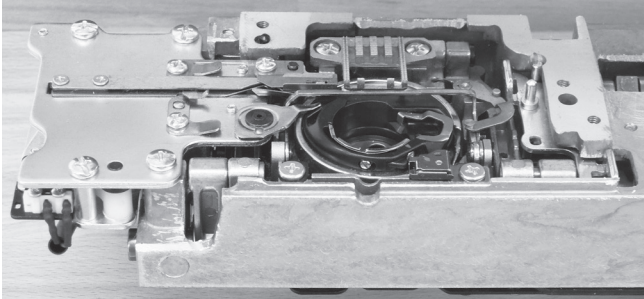

To check:

1. Remove the bed cover and free arm cover (refer to pages 3 to 5).
2. Turn the power switch ON.
The moving cutter motor is initialized, and moving cutter moves to its home position automatically.
3. The distance between the end of moving cutter and the end of thread cutter plate slit should be 0.7 to 1.5 mm.
If not, adjust it as follows.

To adjust:

1. Turn the power switch OFF. Loosen the setscrew on the sensor plate.
2. If the distance is smaller than 0.7 mm, move the sensor plate in the direction of A.
If the distance is larger than 1.5 mm, move the sensor plate in the direction of B.
3. Turn the power switch ON to initialize the cutter position and check if the distance is within 0.7 to 1.5 mm.
4. Attach the free arm cover and bed cover.

Mechanical Adjustment

Presser bar lifter position

The clearance between the presser foot and the surface of the needle plate should be 6 mm when the presser foot is raised. The presser foot (zigzag foot A) should be in parallel with the slot of the feed dog teeth when attached.

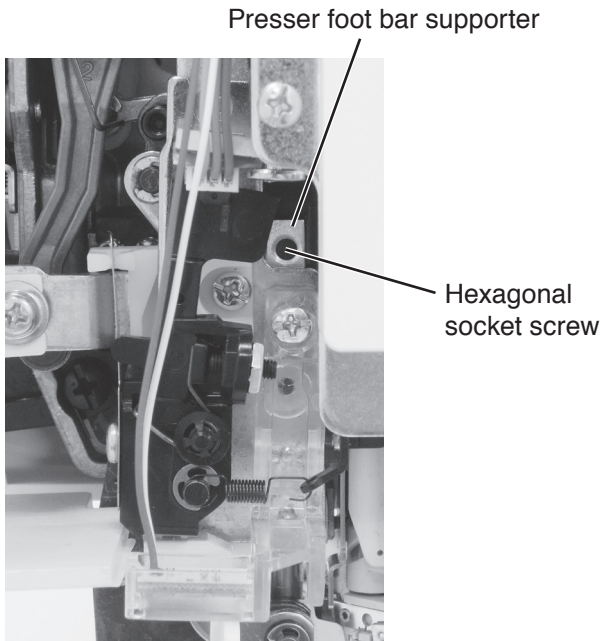

To adjust:

1. Attach the zigzag foot (A).
Lower the feed dog.
2. Turn the power switch ON.
Press the presser foot lifter button to lower the presser foot.
Turn the power switch OFF.
3. Raise the presser foot with the presser foot lifter.
 - * You must use the presser foot lifter to raise the presser foot for this adjustment, otherwise you cannot adjust the presser foot height correctly.

4. Open the face cover.
Place the 6 mm spacer (block) between the presser foot and the needle plate.
Loosen the hexagonal socket screw on the presser bar supporter (use an Allen wrench of 2 mm width across flats).

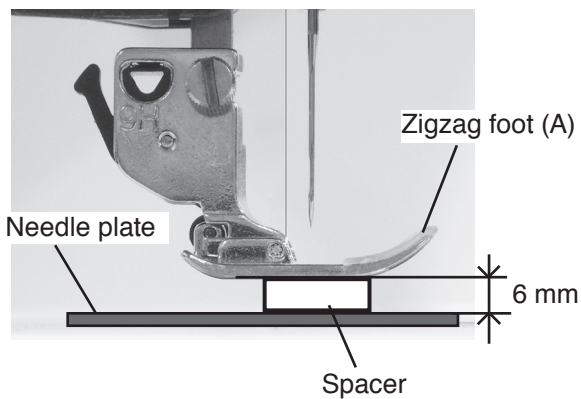

5. Adjust the presser foot (A) direction as illustrated so the slot for the feed dog teeth and the zigzag foot should be parallel.
Tighten the hexagonal socket screw while depressing the foot against the spacer.

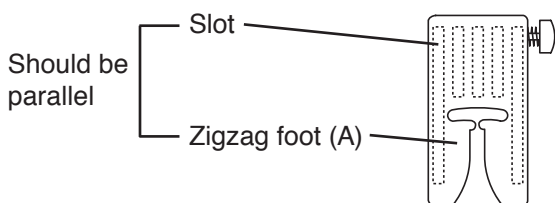

Mechanical Adjustment

Presser foot lifter stopper position (1)

The distance between the presser foot spring release base and the presser foot lifter should be in the range of 39.4 mm to 39.8 mm when the presser foot is raised with the presser foot lifter.

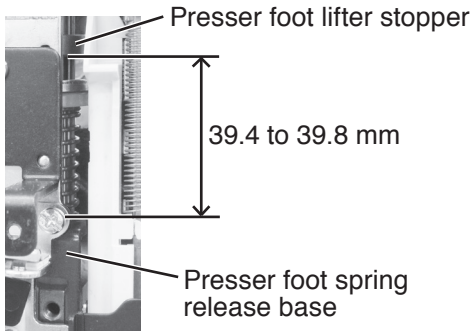

Preparation:

1. Turn the power switch ON.
Press the presser foot lifter button to lower the presser foot.
Turn the power switch OFF.
2. Raise the presser foot with the presser foot lifter.
3. Remove the top cover (refer to page 1).
4. Disconnect the connector from the face cover.
Cut the cord binder.
Loosen the setscrew A.
Remove the setscrews B (2 pcs.) and C.
Remove the carrying handle supporter (front).

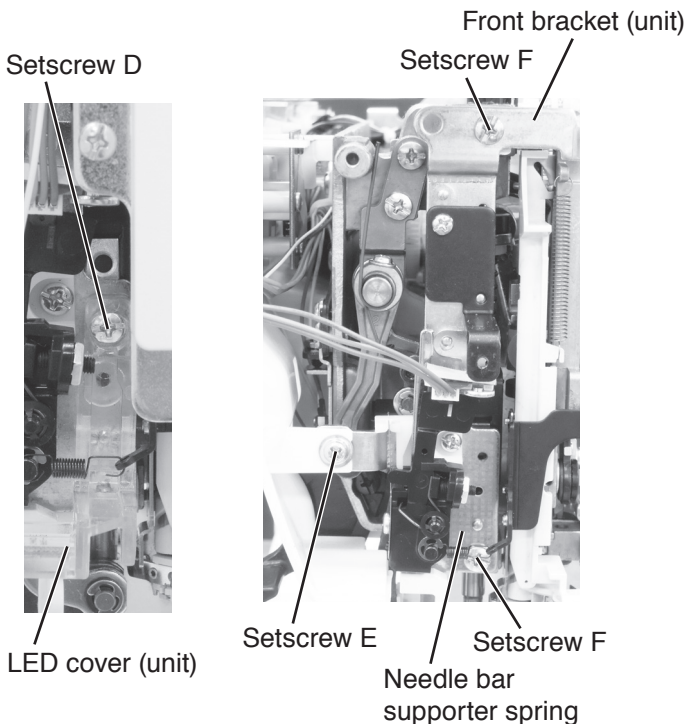
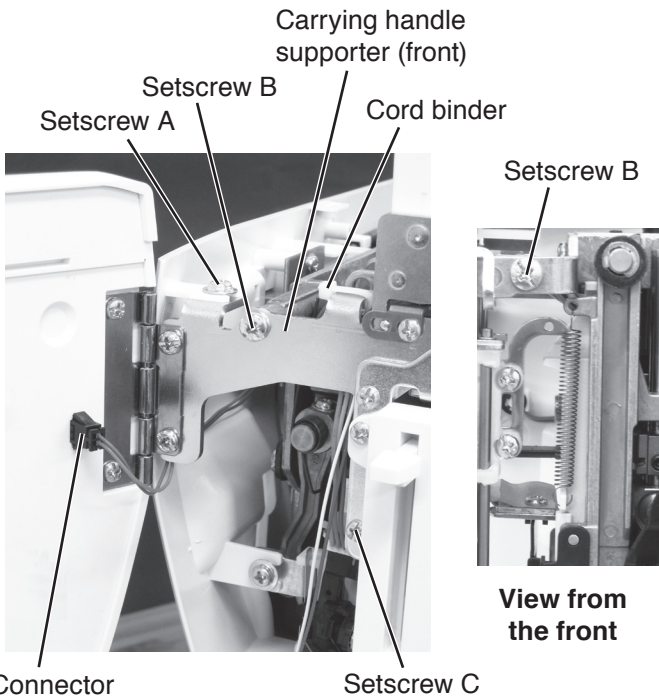

5. Remove the setscrew D and remove the LED cover (unit).
Remove the needle bar supporter spring.
Loosen the setscrew E.
Remove the setscrews F (2 pcs.).
Remove the front bracket (unit).

Mechanical Adjustment

Presser foot lifter stopper position (2)

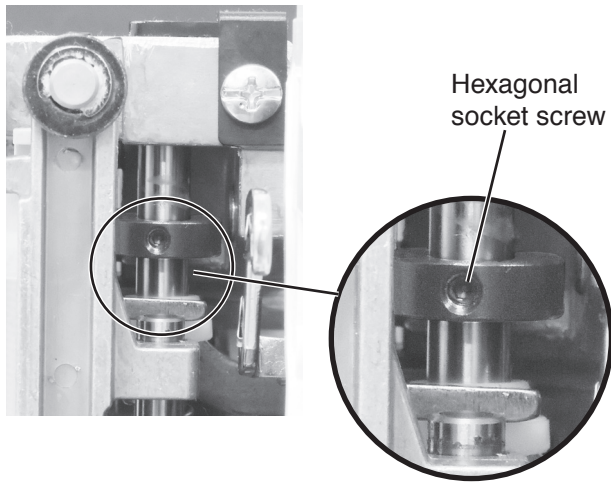

To adjust:

1. Turn the handwheel toward you to lower the needle. Raise the presser foot lifter. Loosen the hexagonal socket screw (use an Allen wrench of 2.5 mm width across flats).
2. Adjust the distance between the presser foot spring release base and the presser foot lifter stopper to 39.4 to 39.8 mm. Tighten the hexagonal socket screw.

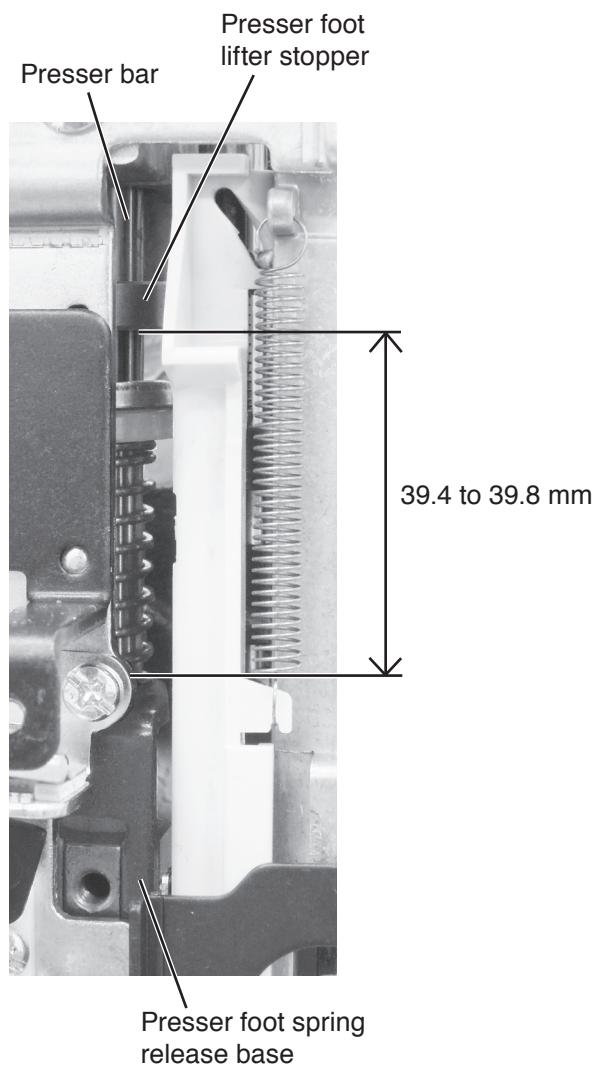

Mechanical Adjustment

Automatic presser foot lifter initializing position

Adjust the foot sensor position when the presser foot lifter motor unit is replaced.

Reverse stitch button

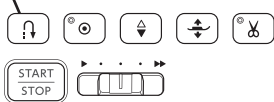

Start/stop button

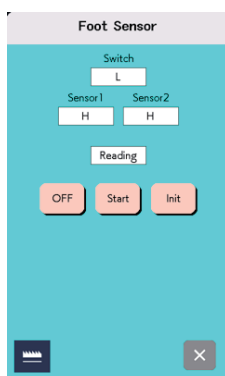
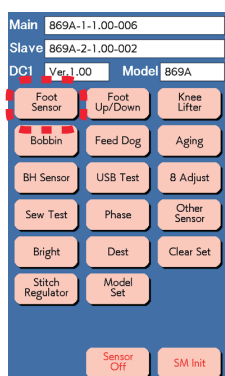

To adjust:

1. Remove the top cover (refer to page 1).
2. Turn the power switch ON while pressing the start/stop button and the reverse stitch button. The LCD shows the factory setting mode. Press the "Foot Sensor" key.



Adjusting screw

Gear

3. Turn the gear A (indicated with black arrow) with your hand to raise the presser foot.
4. Place a 13 mm thick spacer between the presser foot and the needle plate. Lower the presser foot on the spacer firmly by turning the gear.
5. Be sure that the both "Sensor 1" and "Sensor 2" show "H". Press the "Start" key on the touch panel.
 - * In case either "Sensor 1" or "Sensor 2" is not "H", turn the adjusting screw (indicated with white arrow) clockwise until the both "Sensor 1" and "Sensor 2" show "H".
6. Turn the adjusting screw counterclockwise until a beep sound and the "OK" message is shown.

Mechanical Adjustment

Preseer foot height on needle plate

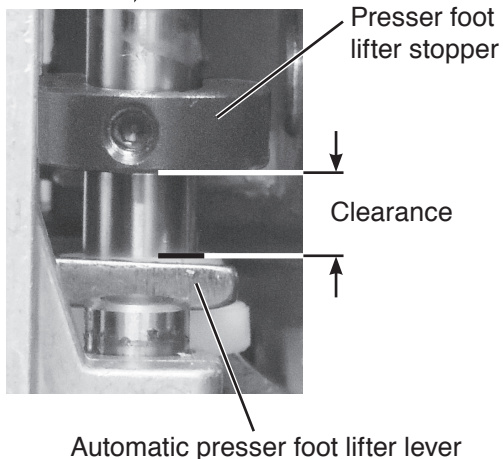
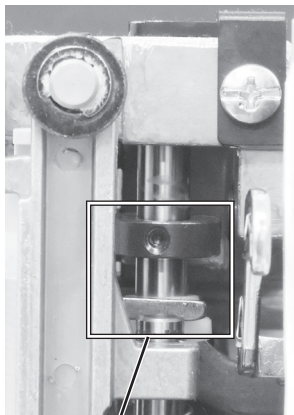
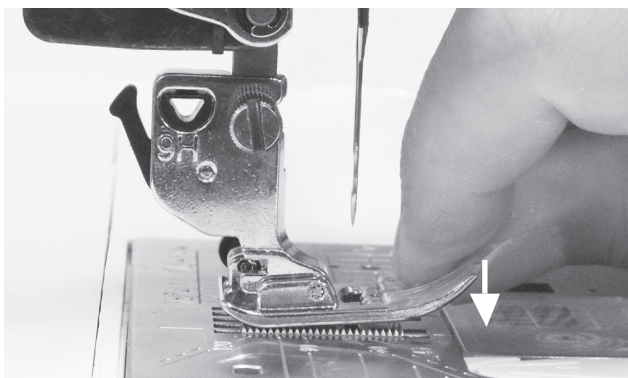
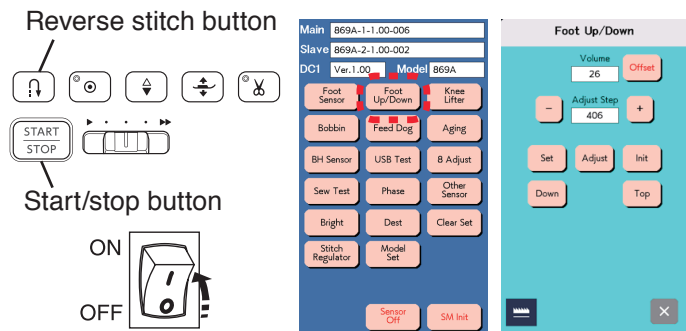

To adjust:

1. Turn the power switch ON while pressing the start/stop button and the reverse stitch button. The LCD shows the factory setting mode. Press the "Foot Up/Down" key.
2. Attach the foot holder lightly (Do not tighten the thumbscrew firmly).
3. Press the "Down" key. The presser bar will be lowered. Tighten the thumbscrew firmly.
4. Press the "Init" key to initialize the settings. Press the "Adjust" key to lower the foot. There should be no gap between the foot and needle plate, but no pressure applied to the needle plate. Check it by tapping the toe of the foot with fingertip as shown.
5. If there is a gap, press the "+" key to lower the foot until the foot lands on the needle plate without the gap.
6. If the foot depress the needle plate, press the "-" key few times to raise the presser foot, then press the "+" key to lower the foot until the foot lands on the needle plate without the gap.
 - * Adjust the presser bar height always by pressing "+" key. Do not press the "-" at the end of this adjustment.
 - * The value of "Adjust Step" should be within the range of 970 to 1030. If the value is far out of the range, check automatic presser foot lifter initializing position adjustment (refer to page 37).
7. Turn the power switch ON again to enter the ordinary sewing mode, and set the presser foot pressure to "Auto-5". Press the presser foot button to lower the presser foot. Be sure that there is a clearance between the presser foot lifter stopper and the automatic presser foot lifter lever as shown in the picture.
 - * If there is no clearance between the presser foot lifter stopper and the automatic presser foot lifter lever, adjust the presser bar height again.

Mechanical Adjustment

Stretch stitch feed balance

Adjust the stretch stitch balance dial at the setting mark.

The measurement of five of test patterns should be in the range of 33 to 39 mm as shown.

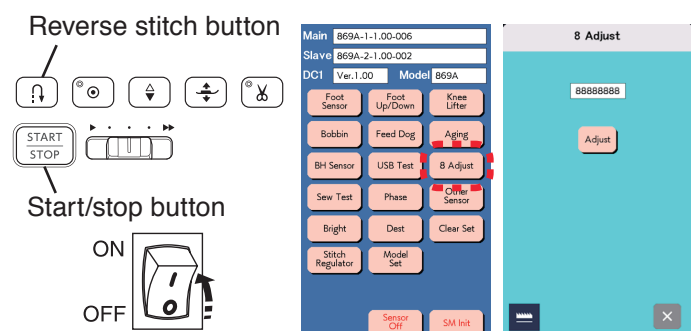

To adjust:

1. Turn the power switch ON while pressing the start/stop button and the reverse stitch button. The LCD shows the factory setting mode. Press the "8 Adjust" key.

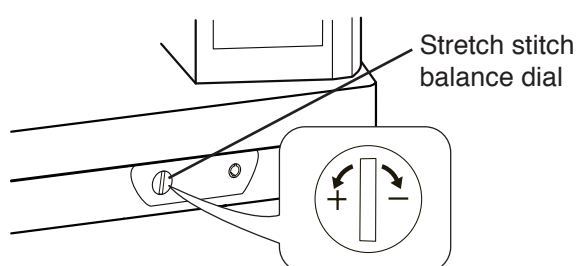

Incorrect Correct Incorrect

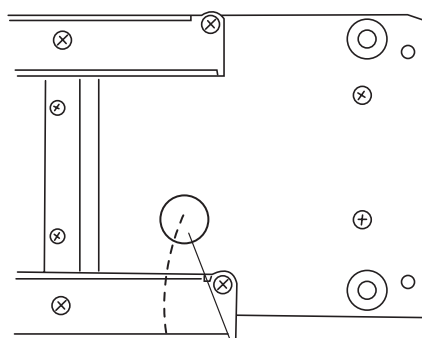
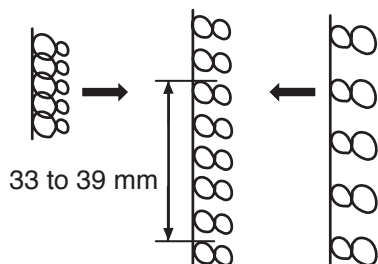

Base lid C

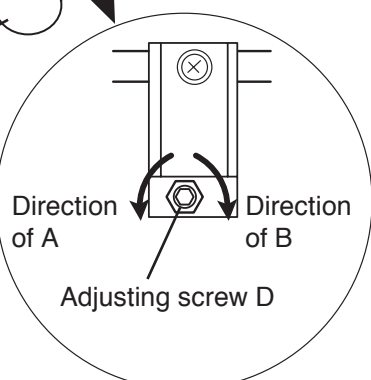

2. Set the stretch stitch balance dial vertical.
3. Attach the satin stitch foot F. Sew test patterns and measure the length of the 5 patterns. The length should be 33 mm to 39mm.
4. If not, remove the base lid C. Press the "Adjust" key so the adjusting screw D comes to the adjusting position.
 - * Turn the adjusting screw in the direction of A if the length is more than 39 mm.
 - * Turn the adjusting screw in the direction of B if the length is less than 33 mm.
5. Sew the test pattern and measure the length of the 5 patterns.
6. Attach the base lid and turn the power switch OFF.

Mechanical Adjustment

Needle plate sensor position

Adjust the needle plate sensor position when the needle plate sensor unit is replaced.

Fig. 1

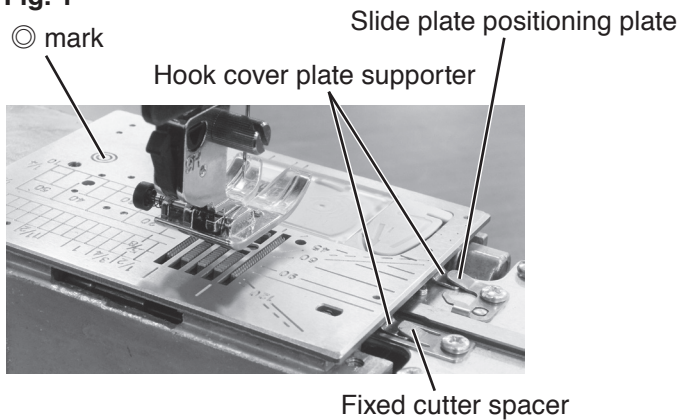

Preparation:

1. Prepare the needle plate and the needle plate for straight stitch.
2. Insert the hook cover plate supporter under the fixed cutter spacer and the slide plate positioning plate. Press the © mark to attach the needle plate.

Fig. 2

Needle plate sensor unit

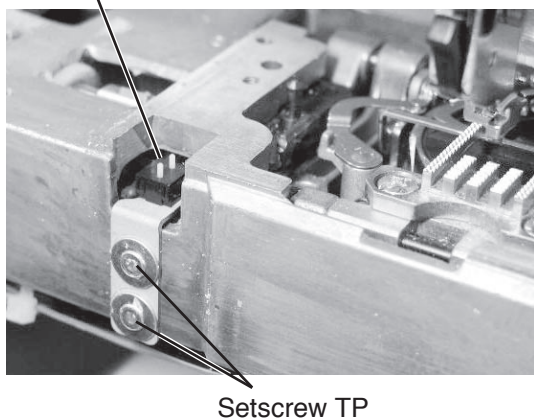

To remove:

1. Remove the base cover, bed cover and the free arm cover (refer to pages 3 to 5).
2. Disconnect the connector from the needle plate switch from the printed circuit board A (refer to page 11).
3. Remove the setscrews TP (2 pcs.) and the needle plate sensor unit.

To attach:

4. Attach the needle plate sensor unit with the setscrews TP (2 pcs.). Tighten the setscrews TP (2 pcs.) lightly.
5. Connect the needle plate sensor connector to the printed circuit board A.
6. Check the needle plate sensor and adjust as necessary (see the adjustment procedure below).
7. Tighten the setscrews TP (2 pcs.) firmly.

Fig. 3

11 to 11.5 mm

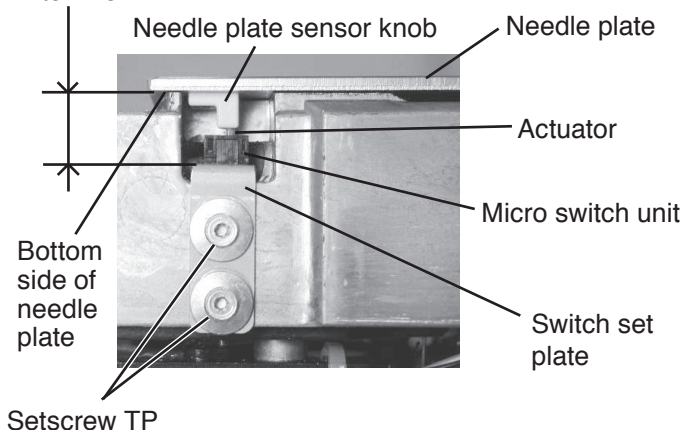

To adjust:

8. The distance between the bottom side of the needle plate and the switch set plate should be in the range of 11 to 11.5 mm. If not, loosen the setscrews TP (2 pcs.) and move the switch set plate up or down to adjust it. Tighten the setscrews TP firmly after the adjustment. The actuator of the micro switch should be aligned with the needle plate sensor knob as shown in fig 3.
9. Attach the free arm cover, bed cover and base cover.

Mechanical Adjustment

Knee lifter position

Adjust the knee lifter position when the knee lifter sensor unit and printed circuit board A are replaced.

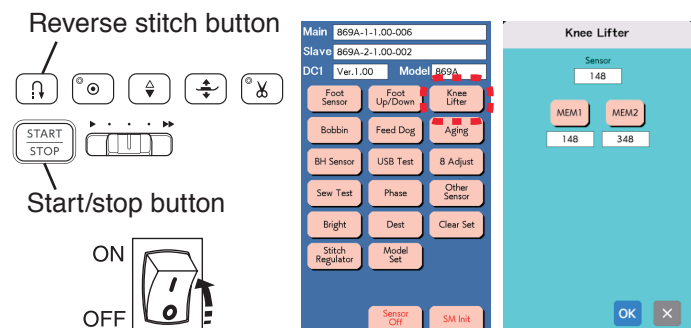

To adjust:

1. Turn the power switch ON while pressing the start/stop button and the reverse stitch button. The LCD shows the factory setting mode. Press the “Knee lifter” key.

Knee lifter is free.



2. Attach the knee lifter. Press the “MEM1” key when the knee lifter is free.

Push the knee lifter to the right as far as it goes.



3. Push the knee lifter to the right as far as it goes. Hold the knee lifter and press the “MEM2” key.
4. Press the “OK” key.

Mechanical Adjustment

Embroidery foot height

Reverse stitch button



Start/stop button

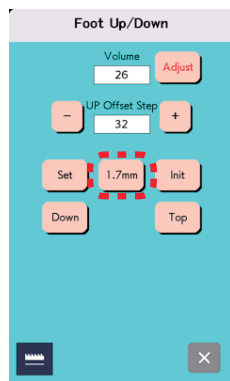
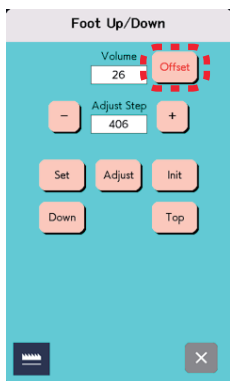
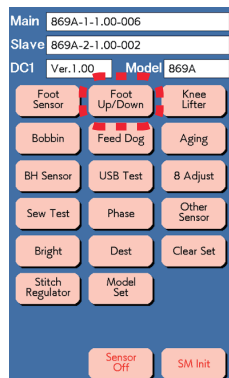

To adjust:

1. Attach the embroidery foot (P).
2. Turn the power switch ON while pressing the Start/ Stop button and the reverse button to enter the factory setting mode. Press the “Foot Up/Down” key.
 - * The presser foot will rise if it is lowered.
3. Press the “Offset” key. The “Offset” key changes to “Adjust”.
4. Press the “1.7 mm”. The embroidery foot will be lowered.
5. Press the “+” or “-” to adjust the distance between the lower edge of the embroidery foot and the surface of the needle plate to 1.7 mm. Adjust the embroidery foot height slightly higher than 1.7 mm so the adjustment can be finished by pressing “-” key at the end.
 - * This adjustment must be completed by pressing “-”.
 - * Press the “-” to raise the presser foot bar.
 - * Press the “+” to lower the presser foot bar.
6. Press the “Set” key. The embroidery foot height will be registered. Press the “X” key to exit the adjusting mode.

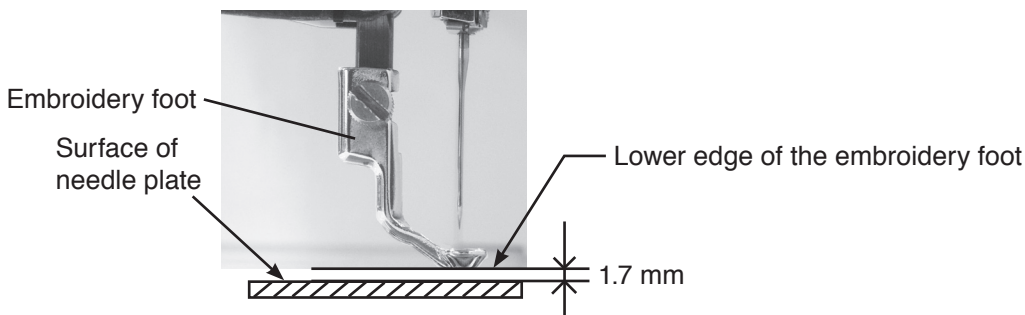

Brightness adjustment

Adjust the screen brightness if the screen is too dark or too bright.

Reverse stitch button



Start/stop button

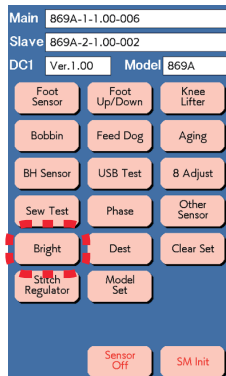

To adjust:

1. Turn the power switch ON while pressing the Start/ Stop button and the reverse button to enter the factory setting mode. Press the “Bright” key.

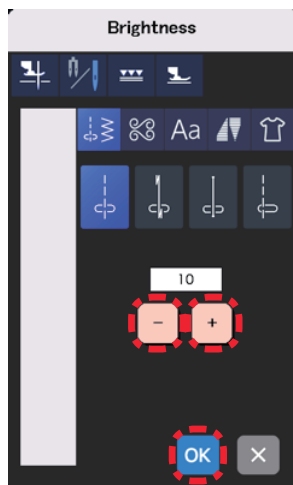

2. Press the “+” key to increase the screen brightness. Press the “-” key to decrease the screen brightness.

* The brightness value can be adjusted from 0 to 17.

3. Press the “OK” key.

Touch panel key position adjustment

Calibrate the key positions of the touch screen if you feel the touch screen key is not responding properly. Refer to the page 142 of the instruction book of this model for the touch screen calibration. If the problem persists, make the key position adjustment as follows.

Needle up/down button

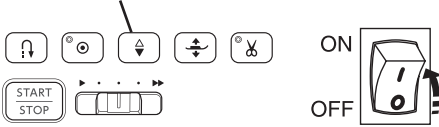

To adjust:

1. Turn the power switch ON while pressing the needle up/down button to enter the touch panel key position adjustment mode.
2. Press the “+” sign as it appears on the touch screen in order of 1 to 5.
3. Be sure that the message “PRESS + marks” changes to “OK”. Repeat the adjustment procedure from step 1 above if the message changes to “NG”.

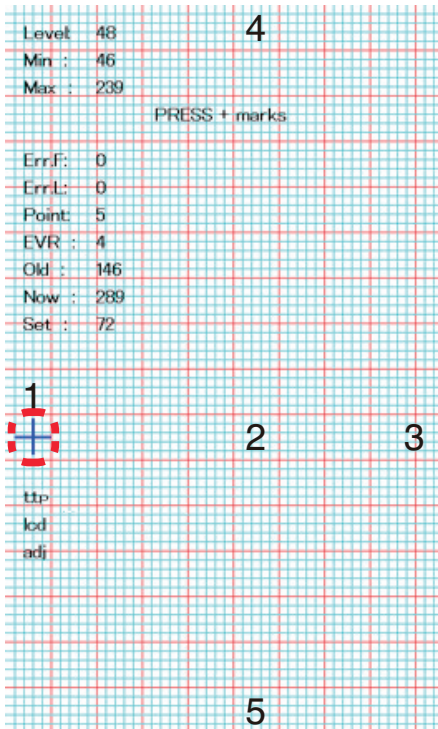

Clear set mode

Before replacing the printed circuit board A, copy the data in the board to a USB flash drive. Some of the machine adjustment may not be required when the saved data is imported to the new printed circuit board A (refer to the following).

[Following adjustments are not necessary if the data is imported to the new board]

To adjust:

- Preseer foot height on needle plate (refer to page 38)
 - Knee lifter (refer to page 41)
 - Embroidery foot height (refer to page 42)
 - Brightness adjustment (refer to page 43)
 - Touch panel key position adjustment (refer to page 44)
- * If the machine will not turn on, or the touch screen is blacked out, perform the above adjustments.

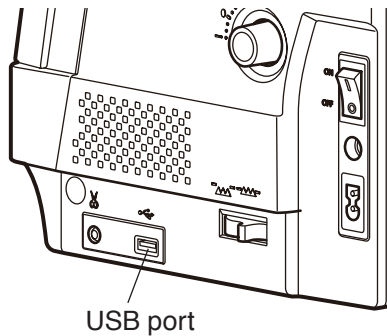
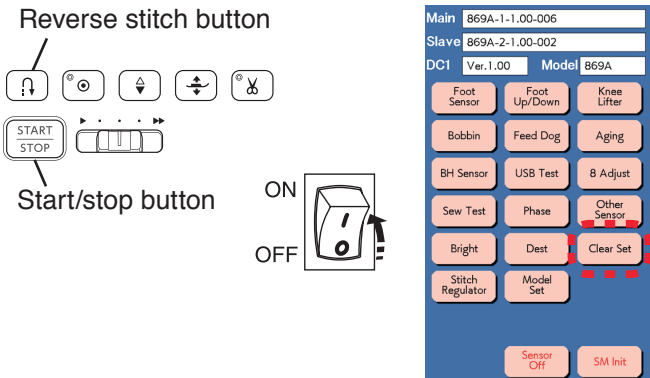

1. Turn the power switch ON while pressing the Start/ Stop button and the reverse button to enter the factory setting mode. Press the „Clear set“ key.
2. Insert a USB flash drive to the USB port. Be sure to format the USB flash drive to “FAT” or “FAT32” before saving the data.
3. Press the „M<->U“ key.
4. Press the “M->U” key to save the board data to the USB flash drive (it may take approximately 10 seconds). Turn the power switch OFF. Remove the USB flash drive from the machine.
5. Replace the printed circuit board A (refer to page 11).
6. Repeat the steps above 1 to 3.
7. Press the “M<->U” key to import the previous board A data to the new board (it may take approximately 10 seconds). The values in the boxes on the screen will change when importing is completed.
8. Turn the power switch OFF. Remove the USB flash drive from the machine.

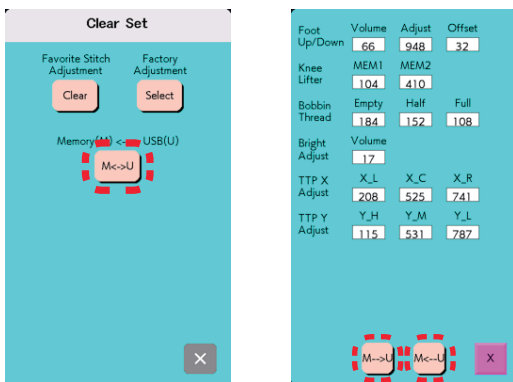

PARTS LIST

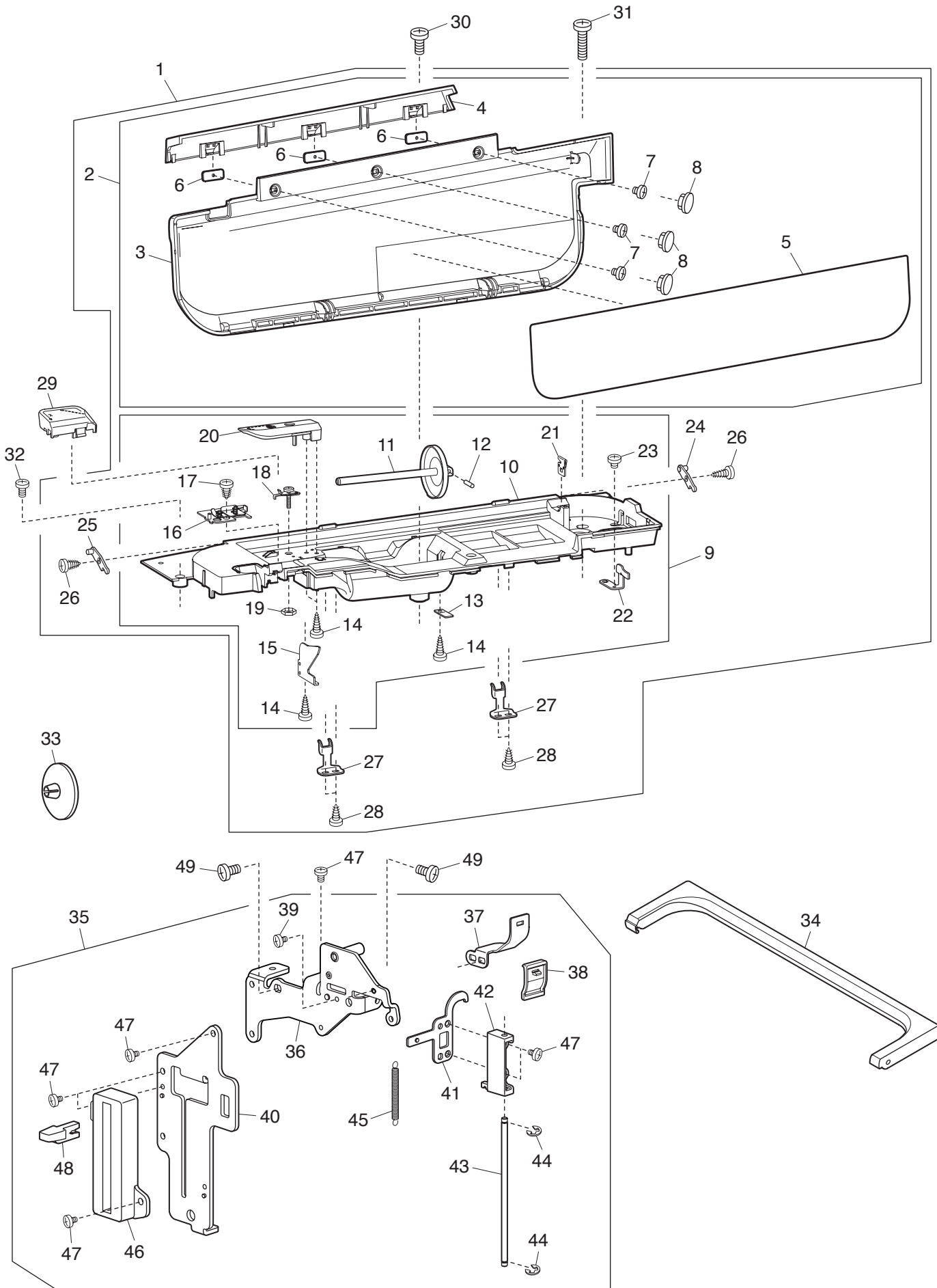

PARTS LIST

KEY NO.	PARTS NO.	DESCRIPTION
1	869602005	Top cover (whole unit)
2	869603006	Top cover (unit)
3	869004001	Top cover
4	869005A01	Top cover ornamental panel
5	869006A01	Reference chart
6	865010008	Washer
7	000103808	Setscrew 3x5
8	862111001	Cap
9	869604007	Top cover body (unit)
10	869007004	Top cover body
11	859052003	Spool pin
12	822017002	Spool pin shaft
13	822018003	Spool pin spring
14	000107204	Setscrew 3x12 (B)
15	862160016	Thread guide plate
16	865606007	Thread guide (unit)
17	000107307	Setscrew 3x8 (B)
18	862535016	Bobbin winder thread guide (unit)
19	000160102	Adjustable lock nut 4
20	862660000	Bobbin winder thread guide cover (unit)
21	830505007	Thread cutter (unit)
22	861099009	Bobbin winder stopper
23	000101127	Setscrew 3x4
24	858023002	Top cover hinge (right)
25	858023105	Top cover hinge (left)
26	000161206	Setscrew 3x10 (B)
27	859137003	Top cover hinge spring
28	000120203	Setscrew 3x8 (B)
29	865013001	Thread guide cover
30	000170507	Setscrew 4x12
31	000104119	Setscrew 4x20
32	000066705	Setscrew 3x8
33	822020503	Spool holder (large)
34	858024003	Carrying handle
35	869619005	Carrying handle supporter (front) (unit)
36	869018008	Carrying handle supporter (front)
37	859067001	Carrying handle spring
38	859238005	Carrying handle spring cap
39	000101105	Setscrew 3x4
40	865023004	Threader base plate
41	869020003	Threader driving plate
42	865025006	Threader bushing
43	865026007	Threader lever shaft
44	000002301	Snap ring E-2
45	865027008	Needle threader return spring
46	865028009	Threader ornamental panel
47	000078319	Setscrew 3x6
48	865029000	Threader lever
49	000081005	Setscrew 4x8

PARTS LIST

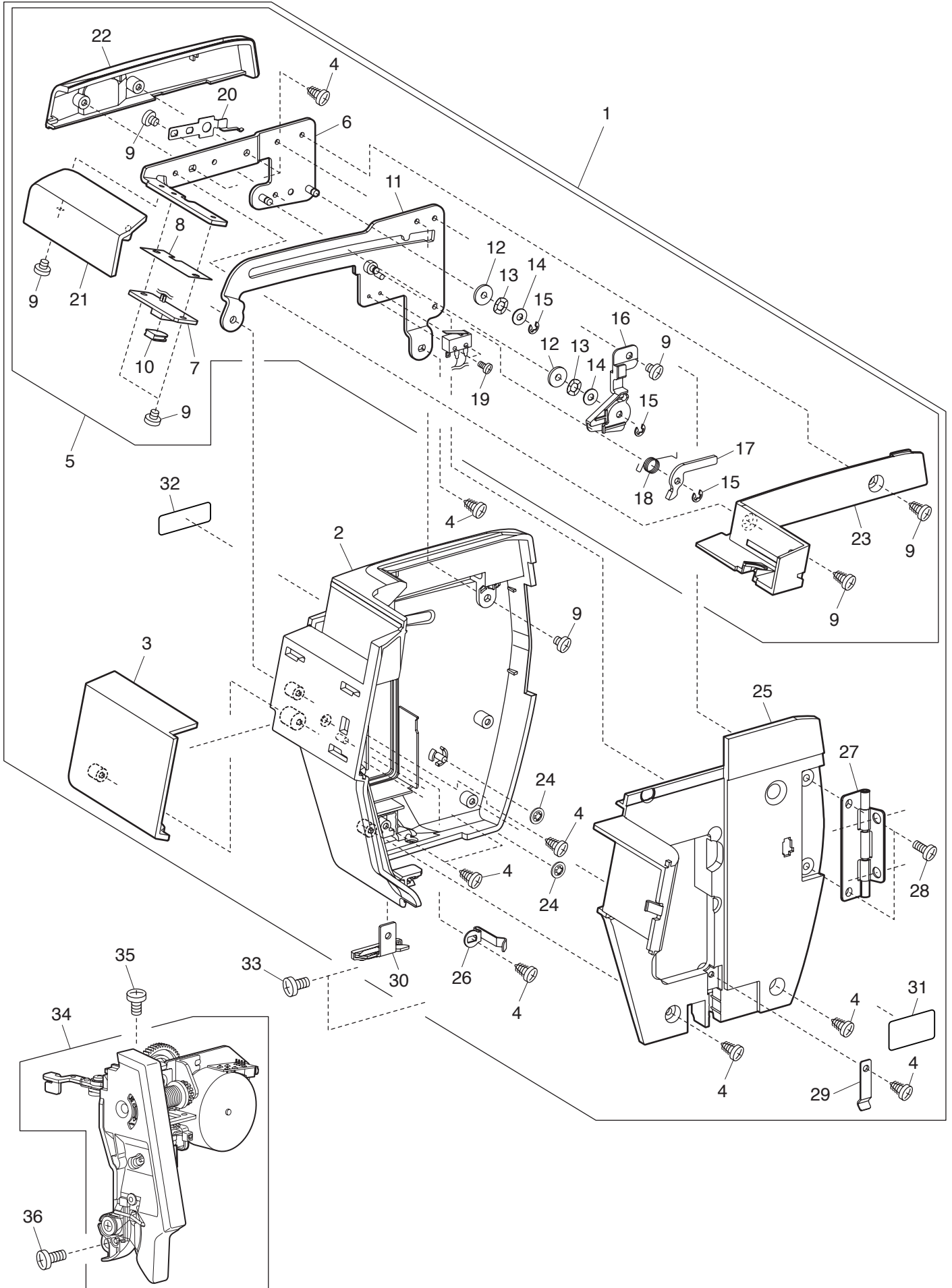

PARTS LIST

KEY NO.	PARTS NO.	DESCRIPTION
1	869605008	Face plate (unit) (U.S.A.) (Canada)
	869605101	Face plate (unit) (Australia) (UK) (Continental Europe)
2	869008A01	Face plate
3	869009109	Ornamental panel
4	000120203	Setscrew 3x8 (B)
5	869620009	Retractable sewing light (unit)
6	869017007	Retractable sewing light arm
7	859505202	Printed circuit board L3 (unit)
8	862142001	Insulation sheet
9	000101105	Setscrew 3x4
10	859060004	Face cover support lamp cover
11	869016006	Face cover lamp guide plate
12	303071000	Ring
13	000116103	Washer 4
14	000070104	Washer 3
15	000001207	Snap ring E-2.5
16	869049008	Cord guide
17	869019009	Switch lever
18	862035000	Switch lever spring
19	000102900	Setscrew 2x8
20	862033008	Index spring
21	869010A01	Retractable sewing light cover 1
22	869011001	Retractable sewing light cover 2
23	869012002	Retractable sewing light cover 3
24	000014306	Snap ring CS-3
25	869013003	Retractable sewing light cover 4
26	850013005	Face plate spring
27	851503103	Face plate hinge (unit)
28	000080406	Setscrew 3x10
29	859233000	Leaf
30	832508017	Thread cutter (unit)
31	100045000	Caution sticker (U.S.A.) (Canada)
32	100517008	Caution sticker (U.S.A.) (Canada)
33	000081119	Setscrew 4x6
34	869612008	Thread tension (unit)
35	000081005	Setscrew 4x8
36	000103509	Setscrew 4x10

PARTS LIST

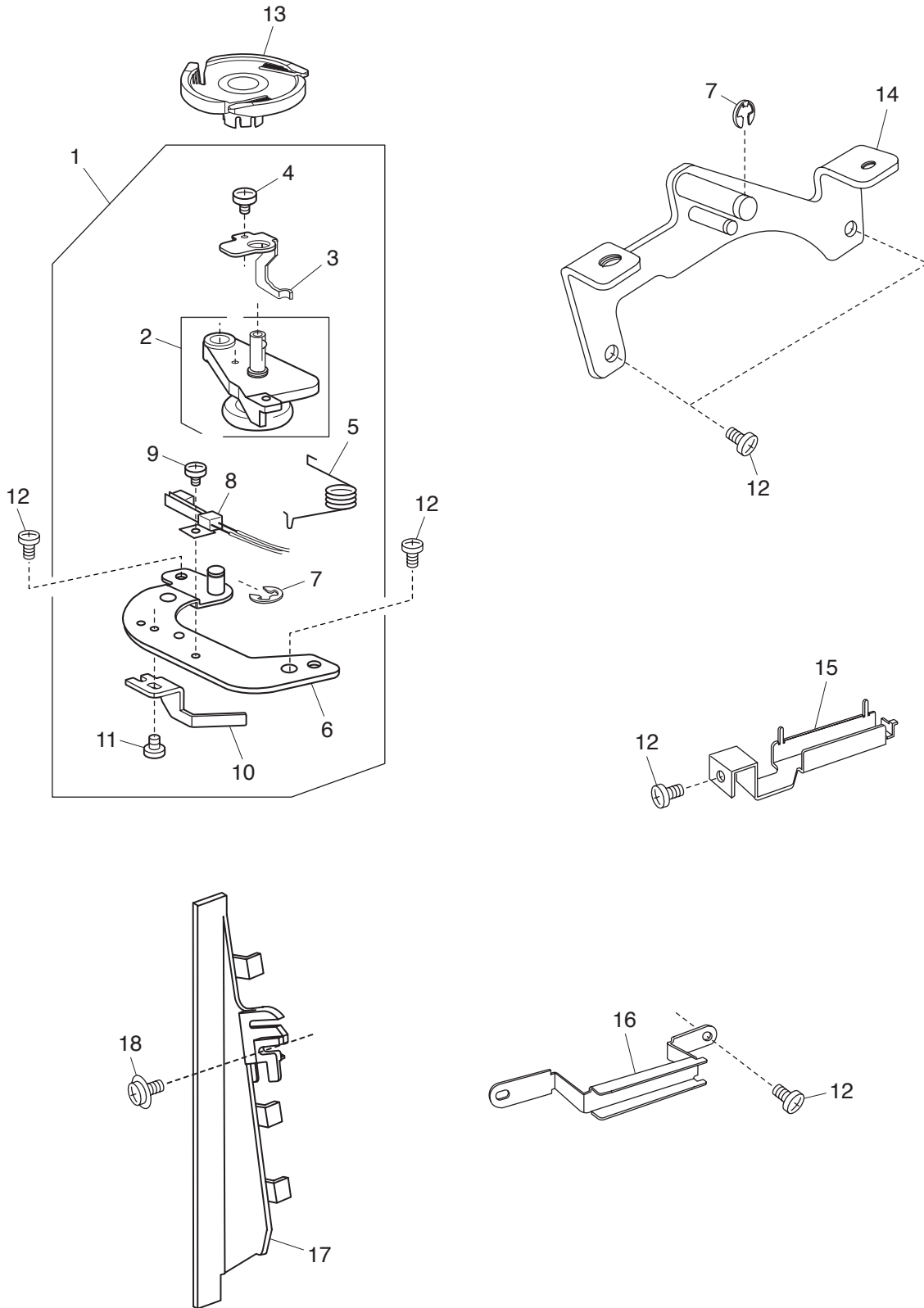

PARTS LIST

KEY NO.	PARTS NO.	DESCRIPTION
1	861636118	Bobbin winder (unit)
2	861503034	Bobbin winder
3	861096006	Clutch lever
4	000120203	Setscrew 3x8 (B)
5	861091001	Bobbin winder arm spring
6	861092002	Bobbin winder set plate
7	000001609	Snap ring E-5
8	856512100	Leaf switch (unit)
9	000081706	Setscrew 2.5x5
10	861098008	Guide plate
11	000101105	Setscrew 3x4
12	000081005	Setscrew 4x8
13	809619009	Thread cutter holder (unit)
14	859134000	Carrying handle supporter (rear)
15	859248008	Upper cord guide
16	858113000	Cord guide
17	858145012	Cord guide plate
18	000115607	Setscrew TP 4x8

PARTS LIST

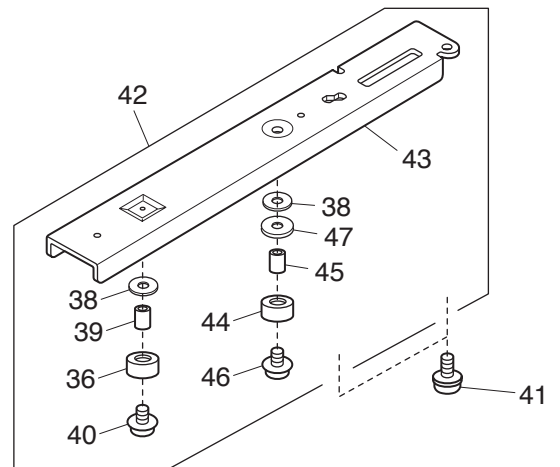
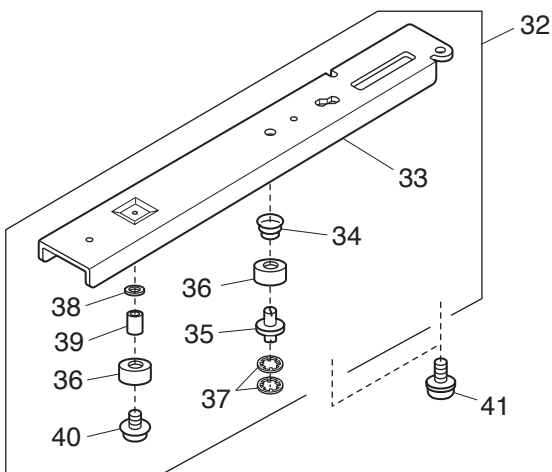
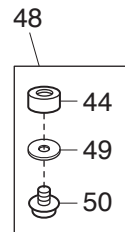
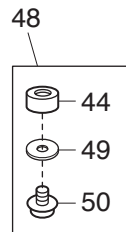
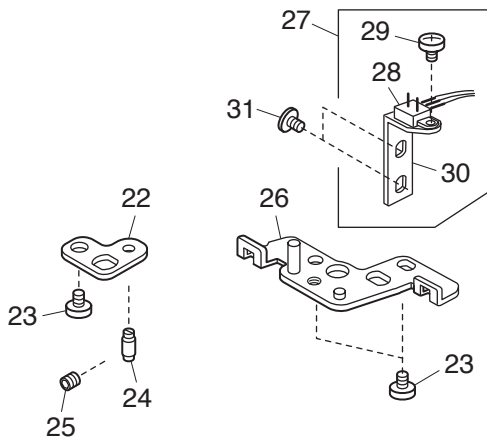
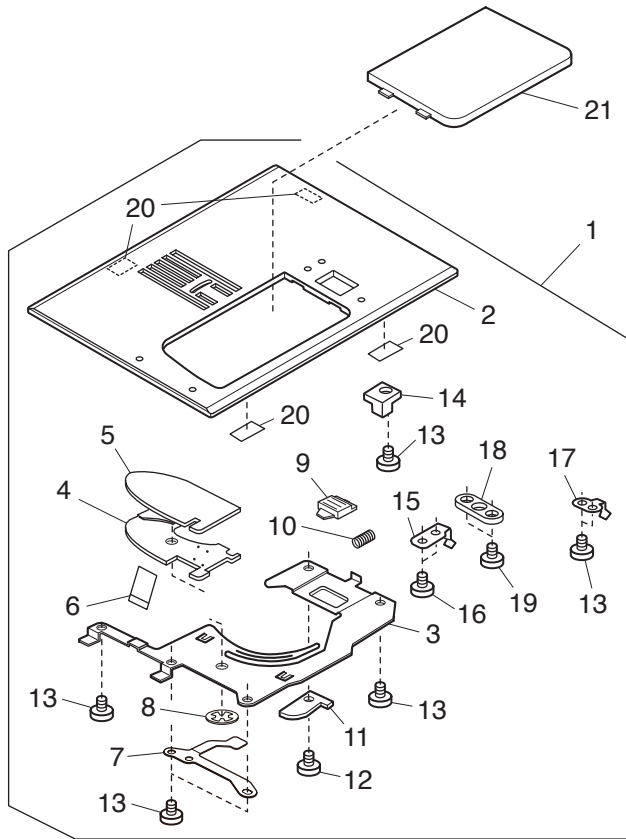

PARTS LIST

KEY NO.	PARTS NO.	DESCRIPTION
1	861606016	Needle plate (unit)
2	861013032	Needle plate
3	861014000	Hook cover plate supporter
4	809134005	Hook cover plate supporter base
5	809135006	Guide holder
6	809137008	Cutter
7	809184000	Leaf
8	000014306	Snap ring CS-3
9	825016000	Hook cover plate release button
10	825017001	Spring
11	809044203	Rotation stopper
12	000097613	Setscrew 2x4
13	820374004	Setscrew 2x2.3
14	859046004	Needle plate sensor block
15	859047016	Needle plate spring
16	000169709	Setscrew 2x2.3
17	859245005	Needle plate spring 2
18	859271000	Needle plate supporter
19	000102807	Setscrew 2x4
20	859272104	Rubber sticker
21	809136100	Hook cover plate
22	860003025	Needle plate nut set plate
23	810220106	Setscrew
24	859270009	Needle plate positioning pin
25	000111201	Hexagonal socket screw 4x4
26	859247018	Needle plate adjusting plate
27	859671107	Needle plate sensor (unit)
28	859524104	Micro switch (unit)
29	755096004	Setscrew
30	859246006	Switch set plate
31	000193001	Setscrew TP 4x6
32	858601011	Arm sole (front) (unit)
33	858002005	Arm sole (front)
34	858162004	Spring
35	820350004	Adjusting screw
36	605074008	Rubber foot
37	000014409	Snap ring CS-8
38	000133106	Washer 6
39	000141107	Bushing 6x3
40	000119106	Setscrew TP 4x10
41	000148403	Setscrew 6x12 (S)
42	858601206	Arm sole (rear) (unit)
43	858002201	Arm sole (rear)
44	797363016	Rubber foot
45	000206709	Bushing 4x7
46	000115700	Setscrew TP 4x10
47	858149005	Spacer 1
48	869622001	Rubber foot (unit)
49	000070300	Washer 5
50	784169009	Rubber foot setscrew

PARTS LIST

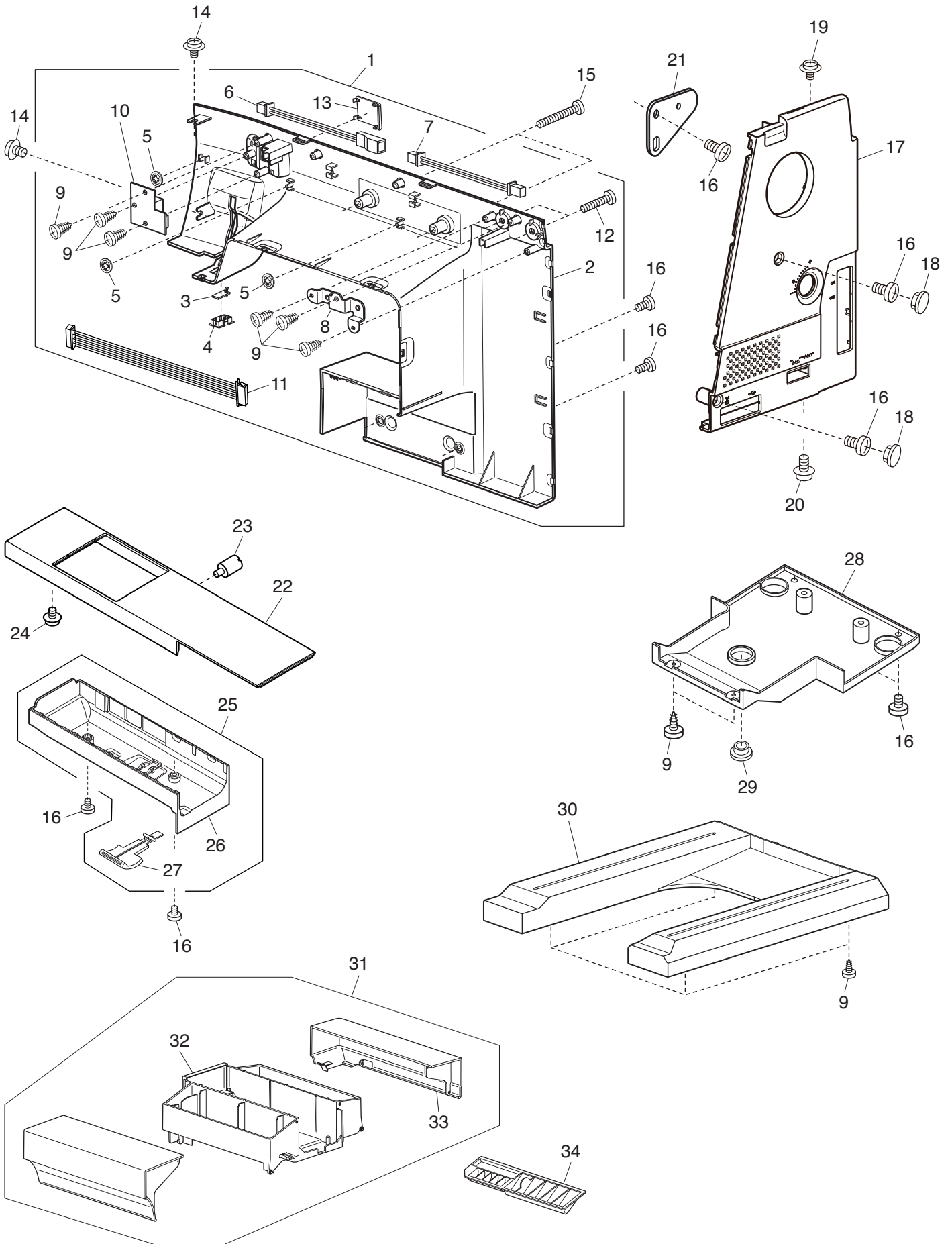

PARTS LIST

KEY NO.	PARTS NO.	DESCRIPTION
1	869601004	Rear cover (unit)
2	869002A01	Rear cover
3	865526013	Printed circuit board L2 (unit)
4	860167006	Lamp cover 2
5	000014306	Snap ring CS-3
6	735516209	Relay cable
7	865505005	Face plate cable (unit)
8	869003000	Spool stand set plate
9	000161206	Setscrew 3x10 (B)
10	868527002	Printed circuit board U (unit)
11	869501003	Relay harness (unit)
12	000104119	Setscrew 4x20
13	868025005	Connector cover (rear)
14	000115205	Setscrew TP 4x6
15	000103222	Setscrew 4x30
16	000081005	Setscrew 4x8
17	869047006	Belt cover
18	745033002	Cap
19	000114709	Setscrew TP 3x6
20	000115607	Setscrew TP 4x8
21	858114001	Belt cover retaining plate
22	862150002	Free arm cover
23	858165007	Pin
24	000114710	Setscrew TP 3x6
25	859614009	Bed cover (unit)
26	859039004	Bed cover
27	859040008	Needle plate release lever
28	858137000	Base plate
29	626045407	Cap
30	865002007	Base cover
31	865602A03	Extension table (unit)
32	865004009	Extension table
33	865006001	Extension table lid (rear)
34	858278015	Foot tray

PARTS LIST

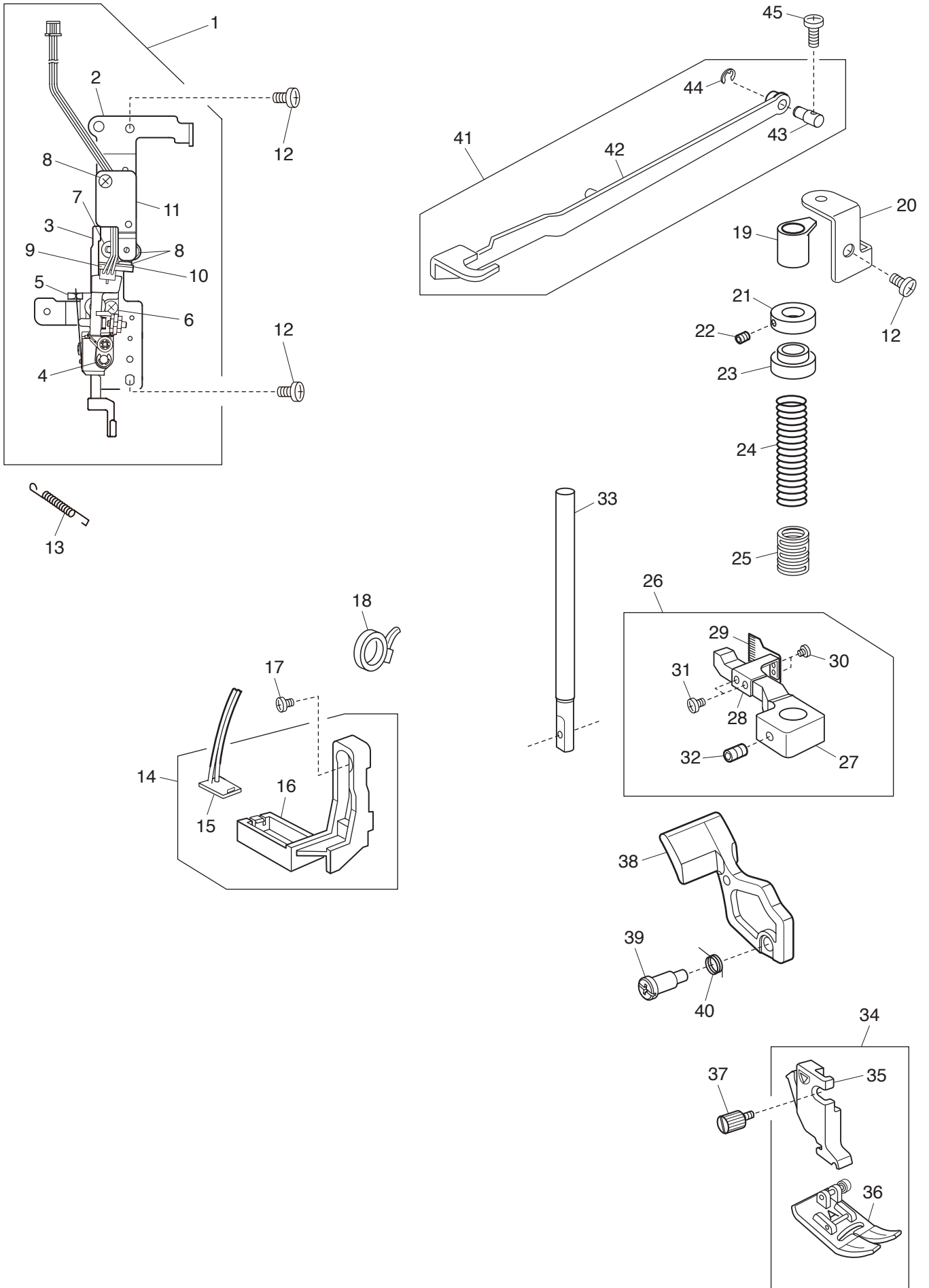

PARTS LIST

KEY NO.	PARTS NO.	DESCRIPTION
1	862621216	Front bracket (unit)
2	862045014	Front bracket
3	808673307	Buttonhole lever (unit)
4	000002105	Snap ring E-3
5	830057021	Buttonhole lever guide
6	000103808	Setscrew 3x5
7	846044002	Sensor base plate
8	000101105	Setscrew 3x4
9	852502921	Printed circuit board G1 (unit)
10	853028002	Insulation sheet
11	865030004	Threader base plate set plate
12	000081005	Setscrew 4x8
13	858312001	Needle bar supporter spring
14	861665806	LED cover (unit)
15	865526002	Printed circuit board L2 (unit)
16	859232021	LED cover
17	000078319	Setscrew 3x6
18	000053008	Cord binder
19	652104004	Presser bar bushing
20	859075002	Presser bar bushing plate
21	859076003	Presser foot lifter stopper
22	000216805	Hexagonal socket screw 3x3
23	859077004	Spring supporter
24	859078005	Presser bar spring
25	859210001	Spring supporter
26	859624105	Presser bar supporter (unit)
27	859079017	Presser bar supporter
28	859240000	Shielding plate set plate
29	867175008	Shielding plate
30	000098108	Setscrew 2x3
31	000128603	Setscrew 3x5
32	000111201	Hexagonal socket screw 4x4
33	859082002	Presser bar
34	867819001	Presser foot (unit)
35	867542000	Presser foot holder (unit)
36	859802006	Zigzag foot (unit)
37	858274000	Thumbscrew
38	869048007	Presser foot lifter lever
39	865049006	Setscrew
40	859029001	Spring
41	863639003	Automatic presser foot lifter lever (unit)
42	859069003	Automatic presser foot lifter lever
43	859070007	Presser foot lifter lever shaft
44	000002507	Snap ring E-4
45	000101703	Setscrew 4x12

PARTS LIST

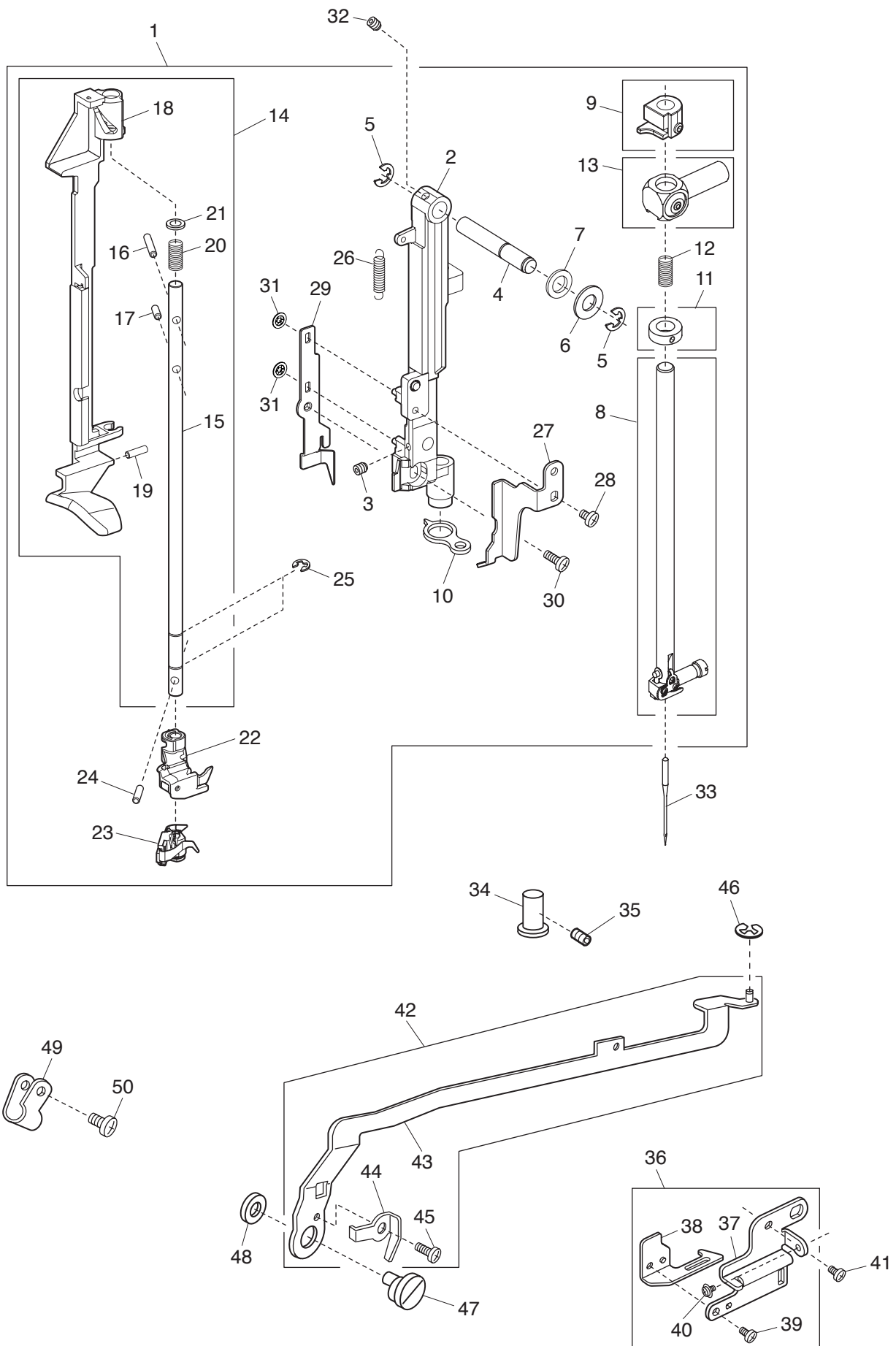

PARTS LIST

KEY NO.	PARTS NO.	DESCRIPTION
1	869606009	Needle bar supporter (unit)
2	869021004	Needle bar supporter
3	000111902	Hexagonal socket screw 3x4
4	735144006	Needle bar supporter pin
5	000002507	Snap ring E-4
6	000070609	Washer 6
7	673022002	Washer
8	858538005	Needle bar (unit)
9	858540000	Rotation pin stopper (unit)
10	829027006	Supporter guide plate
11	858541001	Threader guide ring (unit)
12	869022005	Needle bar supporter spring
13	846515009	Needle bar connecting stud (unit)
14	869608001	Threader shaft (unit)
15	869023006	Threader shaft
16	000265500	Spring pin 2x12-CH
17	000265603	Spring pin 2x6-CH
18	869024A01	Threader arm
19	869025008	Cam pin
20	869026009	Needle threader spring
21	539061004	Washer
22	869609002	Thread guide base
23	869610006	Hook holder (unit)
24	000003508	Spring pin 2x8
25	000001207	Snap ring E-2.5
26	869030006	Needle threader return spring
27	869031007	Spring supporter
28	000103808	Setscrew 3x5
29	869037003	Thread release plate
30	000081500	Setscrew 3x12
31	000014100	Snap ring CS-2
32	000111201	Hexagonal socket screw 4x4
33	647814031	Needle
34	827083004	Supporter guide pin
35	000216805	Hexagonal socket screw 3x3
36	862651019	Arm thread guide (unit)
37	862081012	Arm thread guide
38	862133010	Thread guide plate
39	000101105	Setscrew 3x4
40	000114709	Setscrew TP 3x6
41	000078319	Setscrew 3x6
42	859610005	Zigzag width rod (unit)
43	859031017	Zigzag width rod
44	827088009	Zigzag width rod spring
45	820373003	Setscrew 2x3
46	000002105	Snap ring E-3
47	678084100	Eccentric pin
48	000072014	Washer 5
49	000188405	Nylon clip ACC-2
50	000081005	Setscrew 4x8

PARTS LIST

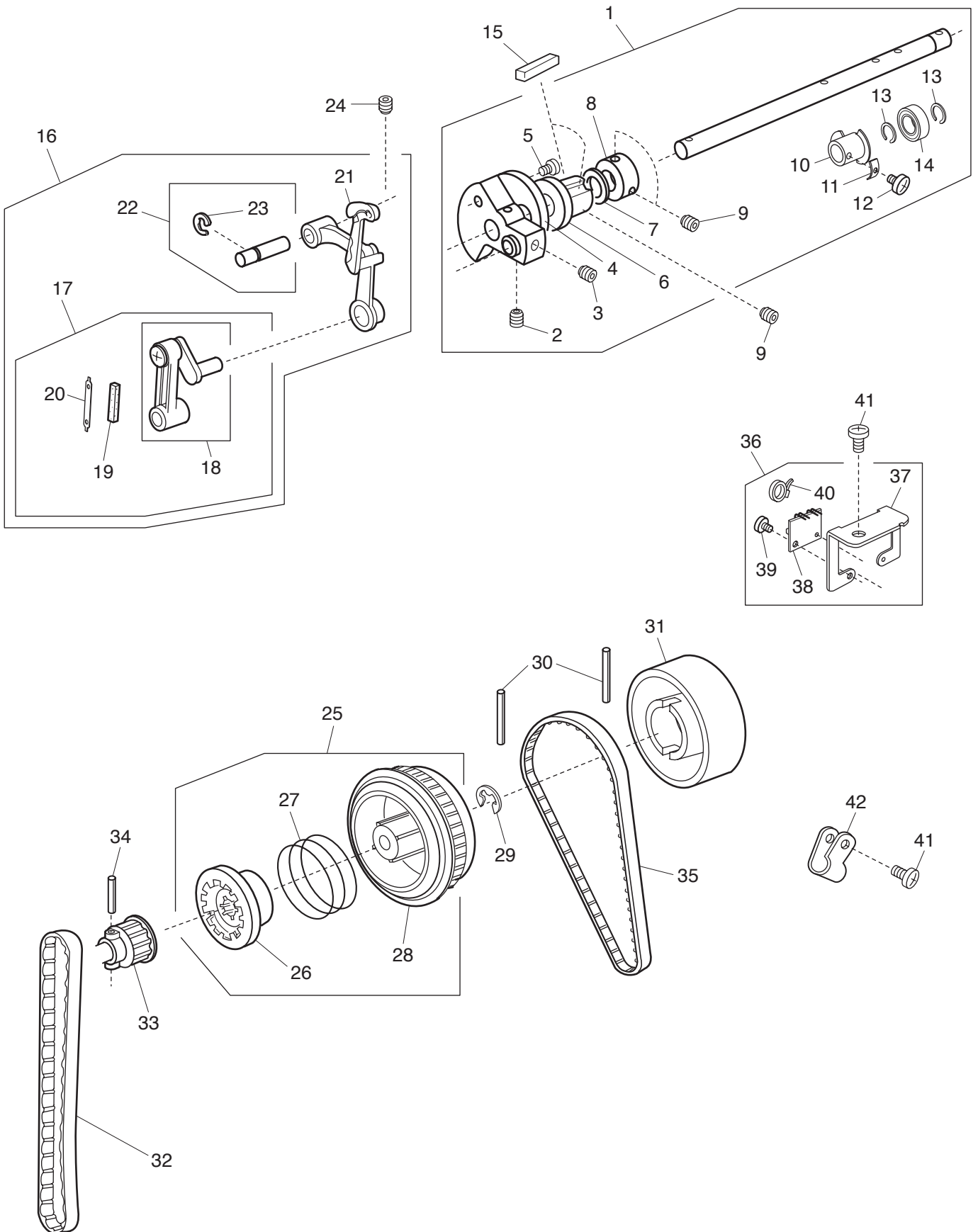

PARTS LIST

KEY NO.	PARTS NO.	DESCRIPTION
1	869618004	Upper shaft (unit)
2	000111706	Hexagonal socket screw 5x8
3	000110901	Hexagonal socket screw 5x4
4	859214005	Upper feed lifting cam
5	000078319	Setscrew 3x6
6	670079201	Upper shaft front bushing
7	000040105	Washer
8	767077006	Ring
9	000111304	Hexagonal socket screw 5x5
10	862002008	Upper shaft shield plate
11	859033008	Washer
12	000080406	Setscrew 3x10
13	000032702	Snap ring crescent
14	767178008	Ball bearing
15	731312005	Felt
16	865618002	Thread take-up lever (whole unit)
17	846615103	Needle bar crank (unit)
18	843543007	Needle bar crank pin (unit)
19	650040005	Felt
20	650041006	Spring
21	820511108	Thread take-up lever (unit)
22	650626001	Thread take-up lever pin (unit)
23	000002806	Snap ring E-6
24	000111201	Hexagonal socket screw 4x4
25	858647008	Belt wheel (unit)
26	858053001	Clutch ring
27	502065004	Clutch spring
28	858054002	Belt wheel
29	000030009	Snap ring E-10
30	000024206	Spring pin 3x30
31	858055003	Handwheel
32	846098104	Timing belt 178
33	858052000	Upper shaft gear
34	000004303	Spring pin 3x20
35	858118108	Timing belt 168
36	859646011	Upper shaft sensor (unit)
37	859056018	Sensor set plate
38	843505100	Printed circuit board P (unit)
39	000101105	Setscrew 3x4
40	000053606	Cord binder
41	000081005	Setscrew 4x8
42	000188405	Nylon clip ACC-2

PARTS LIST

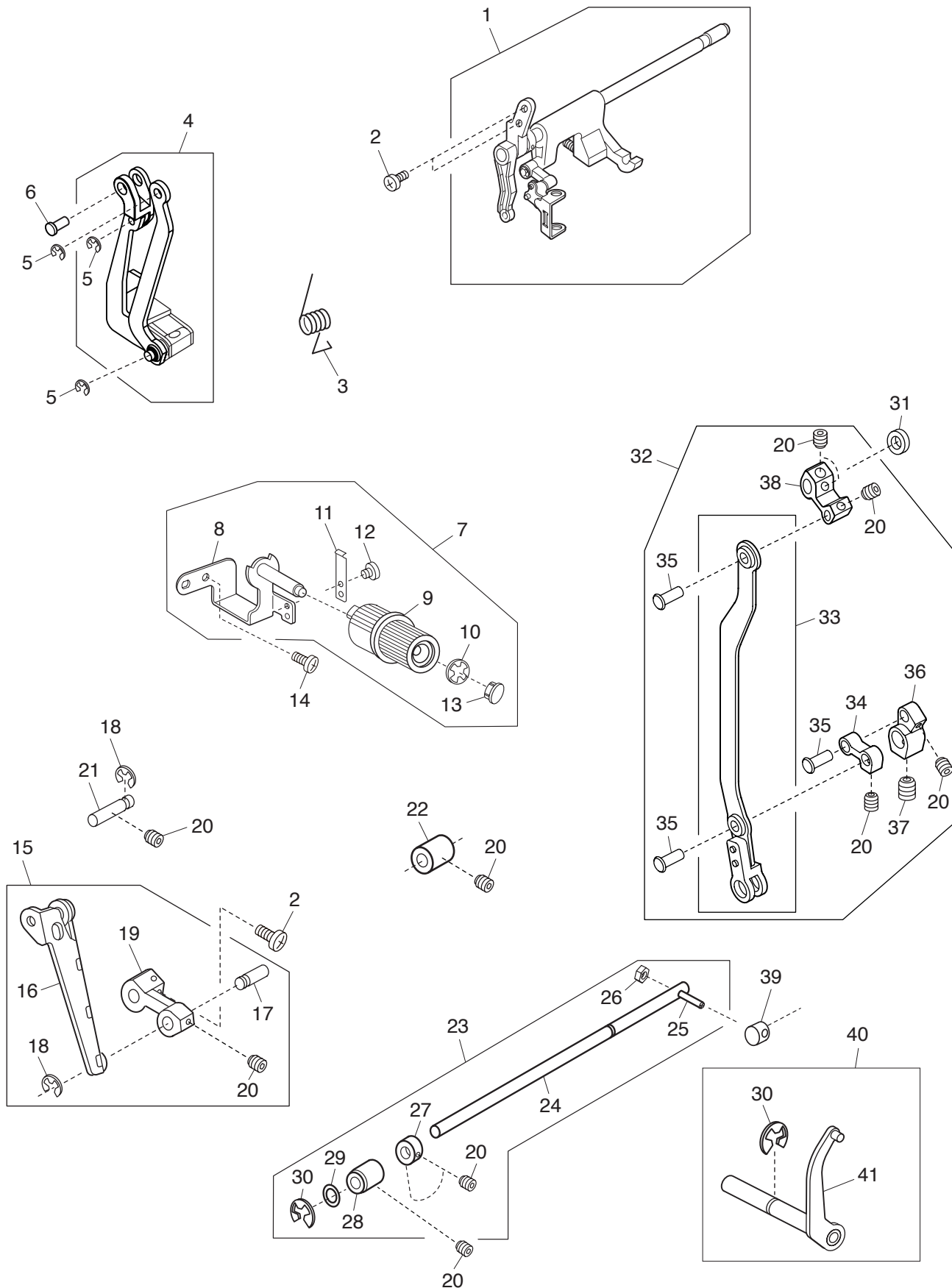

PARTS LIST

KEY NO.	PARTS NO.	DESCRIPTION
1	859640004	Upper feed upper shaft (unit)
2	000103509	Setscrew 4x10
3	858156005	Upper feed upper shaft spring
4	859627027	Upper feed foot (unit)
5	000002105	Snap ring E-3
6	846327002	Pin (1)
7	858625000	Upper feed adjusting base plate (unit)
8	858072006	Upper feed adjusting base plate
9	846351005	Upper feed adjusting dial
10	000014007	Snap ring CS-4
11	846353007	Dial leaf
12	000101105	Setscrew 3x4
13	653006101	Cap
14	000081005	Setscrew 4x8
15	858623008	Feed connecting link (unit)
16	858068009	Feed connecting link
17	502258006	Connecting pin
18	000002507	Snap ring E-4
19	846304106	Upper feed lower shaft front arm
20	000111201	Hexagonal socket screw 4x4
21	502258109	Connecting pin
22	784071003	Looper shaft bushing
23	858624009	Upper feed lower shaft (unit)
24	858069000	Upper feed lower shaft
25	846306005	Upper feed lower shaft rear arm
26	000061102	Nut 4-1-7
27	820166001	Lower shaft ring
28	846303002	Upper feed lower shaft bushing
29	000038502	Washer
30	000002806	Snap ring E-6
31	822070003	Felt (1)
32	846580016	Upper feed adjusting arm (unit)
33	846577009	Upper feed connecting link (unit)
34	846349000	Upper feed adjusting link
35	820144003	Pin
36	846350004	Upper feed adjusting arm (1)
37	000111304	Hexagonal socket screw 5x5
38	863111004	Upper feed upper shaft rear arm
39	846348009	Rear arm feed lifting roller
40	858644005	Upper feed adjusting arm 2 (unit)
41	858070004	Upper feed adjusting arm 2

PARTS LIST

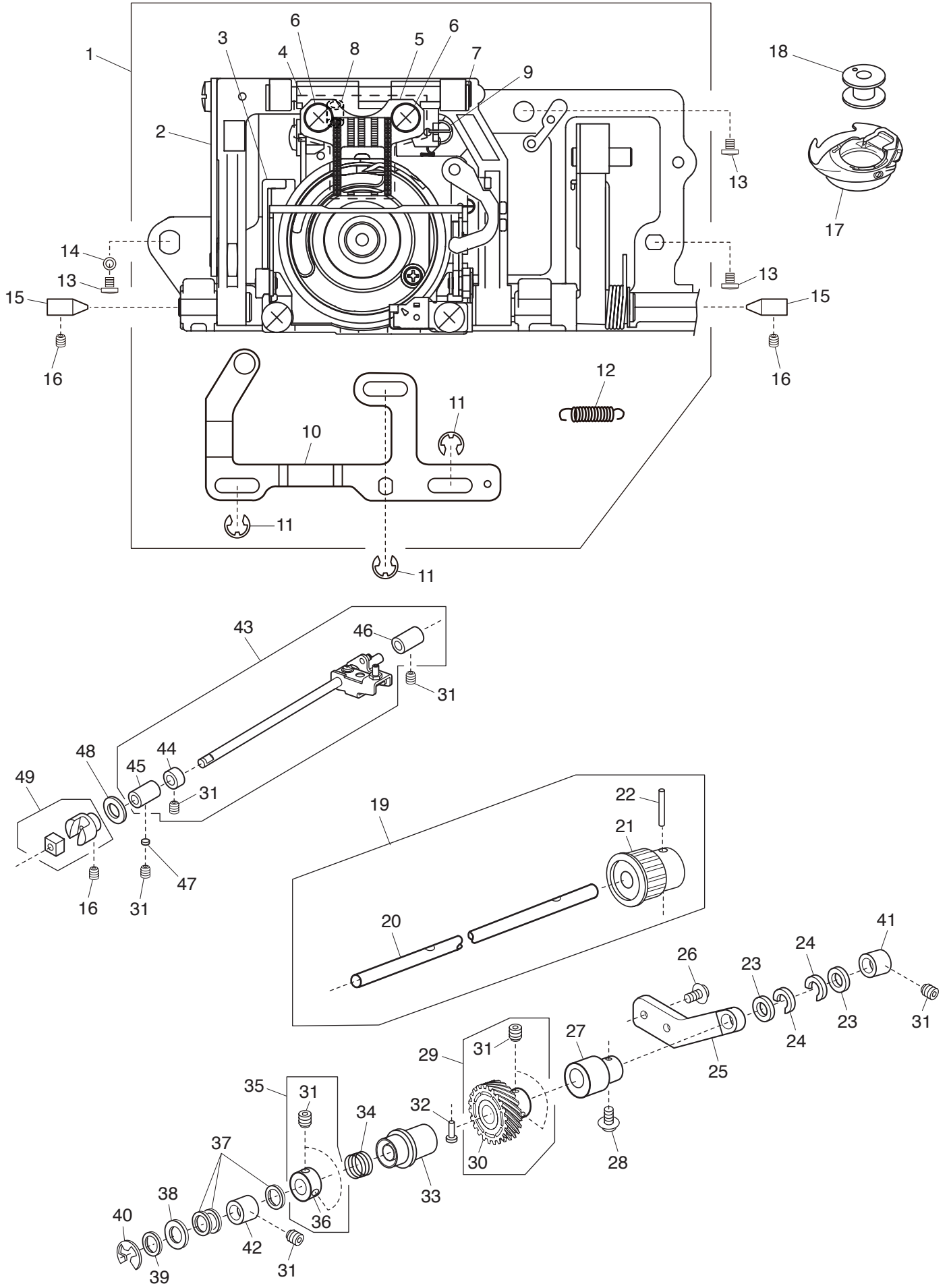

PARTS LIST

KEY NO.	PARTS NO.	DESCRIPTION
1	859637112	Feed rock shaft (whole unit)
2	858621006	Feed rock shaft (unit)
3	859638113	Hook race (unit)
4	859639103	Feed dog set base (unit)
5	867033003	Feed dog
6	000104005	Setscrew 3.5x8
7	825099007	Feed dog base shaft
8	000111407	Hexagonal socket screw 4x6
9	825103005	Feed base spring
10	858138001	Drop plate
11	000002105	Snap ring E-3
12	661018008	Spring
13	000081005	Setscrew 4x8
14	000070506	Washer 4
15	738055008	Straight pin
16	000111304	Hexagonal socket screw 5x5
17	846652102	Bobbin holder (unit)
18	102261103	Bobbin
19	858618000	Lower shaft (unit)
20	858056004	Lower shaft
21	650073007	Lower shaft gear
22	000004200	Spring pin 3x18
23	822070003	Felt (1)
24	822112008	Felt holder (1)
25	858058006	Lower shaft supporter
26	000115700	Setscrew TP 4x10
27	846379009	Feed cam
28	000149600	Setscrew 3x14
29	863663006	Lower shaft gear (unit)
30	808137005	Lower shaft gear
31	000111201	Hexagonal socket screw 4x4
32	820161006	Feed lifting pin
33	846103000	Feed lifting cam
34	825093001	Feed lifting cam spring
35	820672005	Lower shaft ring (unit)
36	820166001	Lower shaft ring
37	000038502	Washer
38	735143005	Felt
39	858177002	Washer
40	000002806	Snap ring E-6
41	650079003	Lower shaft bushing (rear)
42	858060001	Lower shaft bushing (front)
43	869623002	Feed shaft (unit)
44	820387000	Ring
45	625144002	Feed shaft bushing (front)
46	650092002	Feed shaft bushing (rear)
47	650175000	Cushion
48	823110009	Felt
49	625508008	Feed regulator (unit)

PARTS LIST

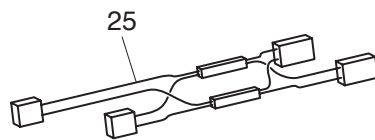
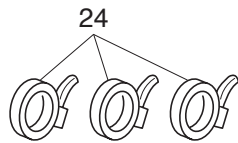
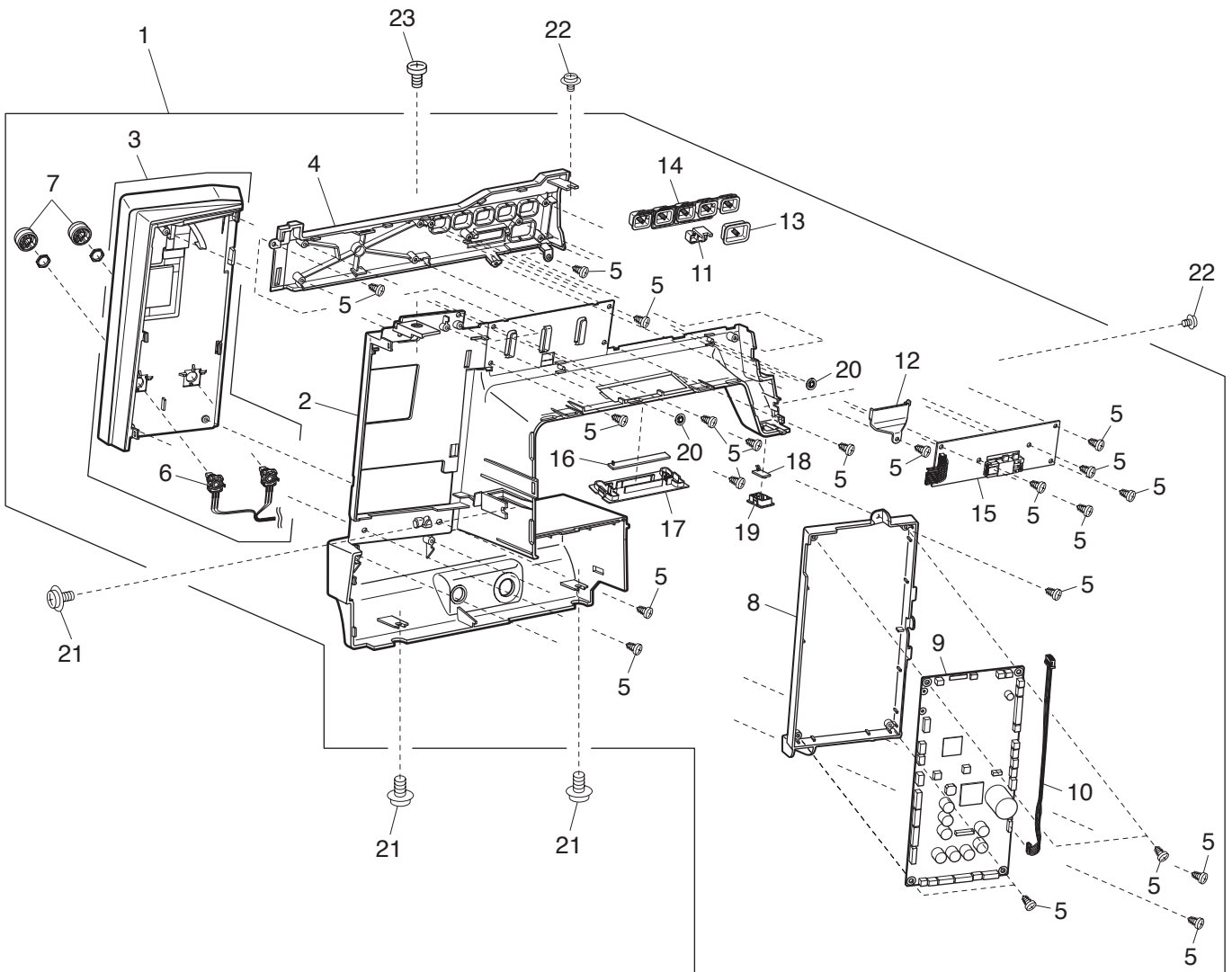

PARTS LIST

KEY NO.	PARTS NO.	DESCRIPTION
1	869614000	Front cover (unit)
2	869040A01	Front cover
3	869615001	Display (unit)
4	869042A01	Ornamental panel
5	000120203	Setscrew 3x8 (B)
6	869503005	Rotary encoder (unit)
7	868614007	Dial (unit)
8	869046005	Printed circuit board A case
9	869413029	Printed circuit board A
10	869509001	Relay harness (unit)
11	868035008	Speed control slider
12	869043002	Speed control slider guide
13	869044A01	Start/stop button
14	869045A01	Function button
15	869506008	Printed circuit board F (unit)
16	865525001	Printed circuit board L1 (unit)
17	858106000	LED cover 2
18	865526024	Printed circuit board L2 (unit)
19	860167006	Lamp cover 2
20	000014306	Snap ring CS-3
21	000115607	Setscrew TP 4x8
22	000114710	Setscrew TP 3x6
23	000103417	Setscrew 4x8
24	000053008	Cord binder
25	865503003	Branch cord

PARTS LIST

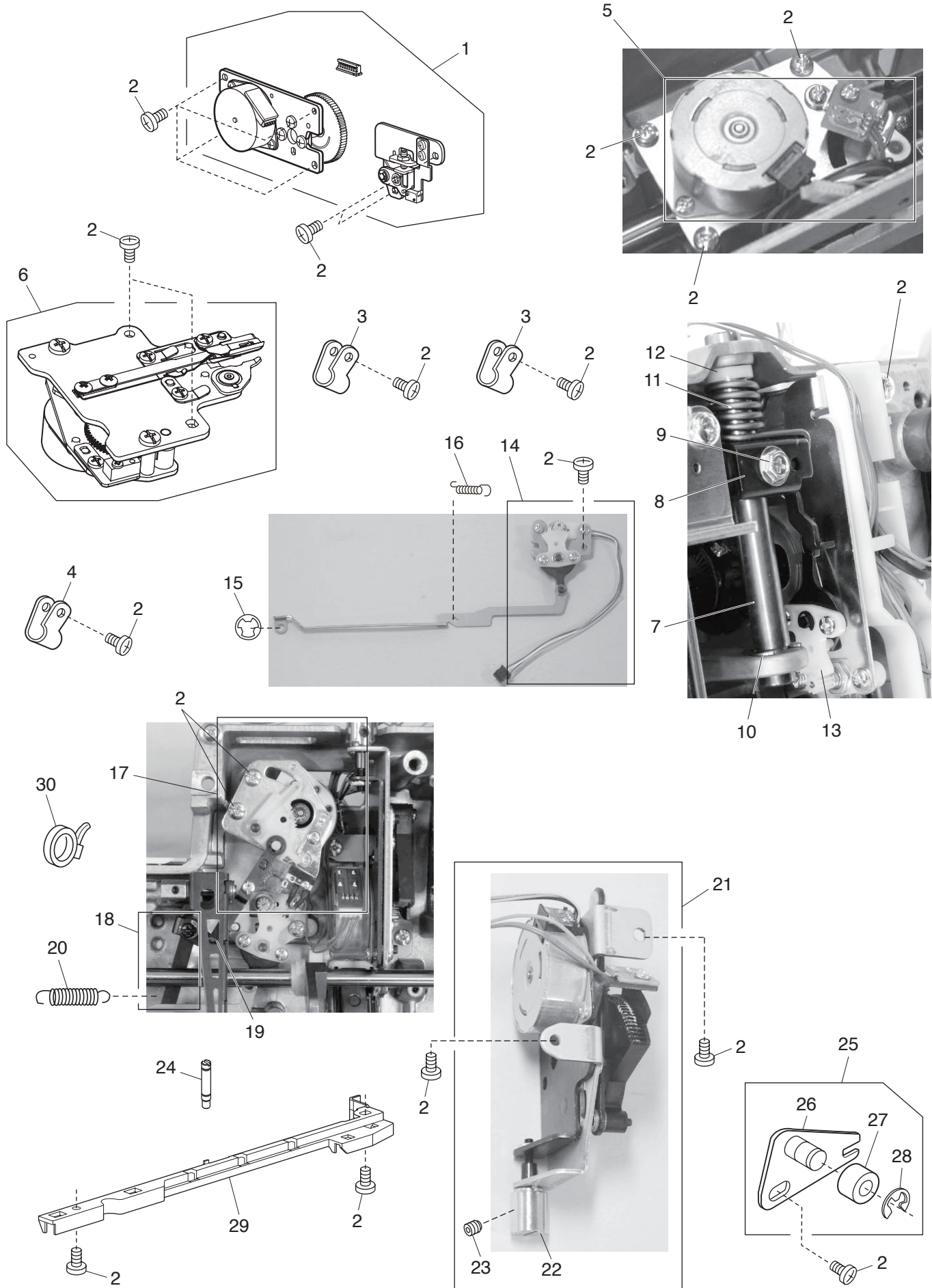

PARTS LIST

KEY NO.	PARTS NO.	DESCRIPTION
1	865614101	Presser foot lifter motor (unit)
2	000081005	Setscrew 4x8
3	000188405	Nylon clip ACC-2
4	000188014	Nylon clip ACC-3.5
5	865616000	Zigzag width motor (unit)
6	863638002	Automatic thread cutter (unit)
7	858088108	Knee lifter shaft
8	859021014	Knee lifter stopper
9	000138503	Hexagonal socket bolt screw 5x12
10	000002208	Snap ring E-9
11	859022004	Knee lifter stopper spring
12	846297002	Stopper
13	859609104	Knee lifter sensor (unit)
14	859606204	Sensor set plate (unit)
15	000013707	Snap ring CS-2.4
16	859011000	Spring
17	865617001	Bobbin thread sensor motor (unit)
18	859605007	Arm (unit)
19	000002105	Snap ring E-3
20	865043000	Spring
21	865615009	Feed motor (unit)
22	859215006	Feed balancing dial
23	000110200	Hexagonal socket screw 4x4 (WP)
24	859260006	Pin
25	860608004	Idler (unit)
26	860021007	Idler base
27	625217100	Idler
28	000002806	Snap ring E-6
29	865041008	Cord guide (free arm cover)
30	000053008	Cord binder

PARTS LIST

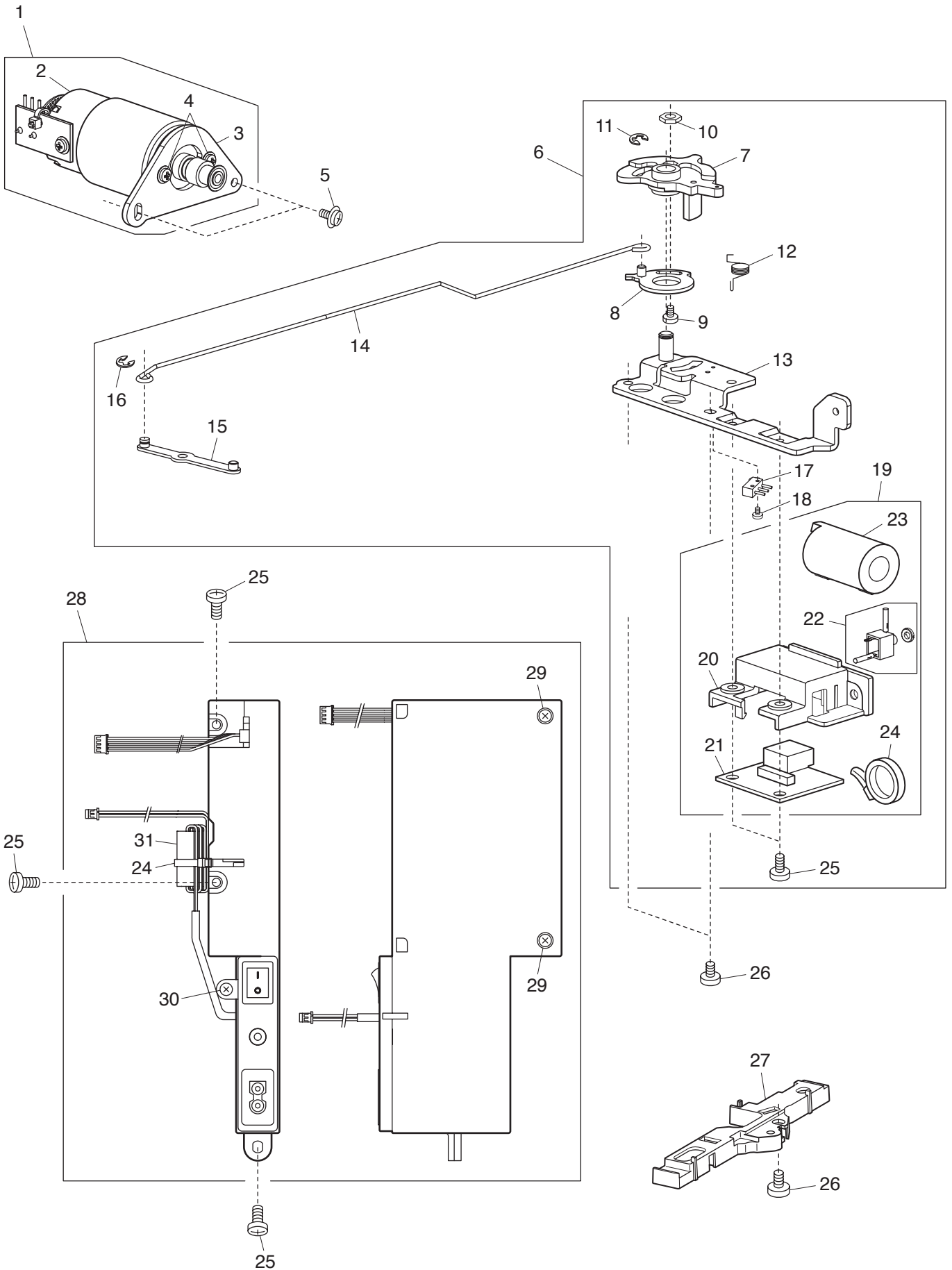

PARTS LIST

KEY NO.	PARTS NO.	DESCRIPTION
1	865613007	DC motor (unit)
2	865504004	DC motor
3	858117004	DC motor set plate
4	000115009	Setscrew TP 3x8
5	000115607	Setscrew TP 4x8
6	865612006	Feed dog drop lever (unit) (U.S.A.) (Canada)
	865612109	Feed dog drop lever (unit) (Australia) (UK) (Continental Europe)
7	858143009	Feed dog drop lever
8	858142008	Feed dog drop lever connecting plate
9	000066705	Setscrew 3x8
10	000061803	Nut 3-3-5.5
11	000002507	Snap ring E-4
12	823119008	Spring
13	865039003	Feed dog drop lever base
14	858279005	Rod
15	858139002	Drop connecting plate
16	000002105	Snap ring E-3
17	846513904	Micro switch (unit)
18	000102900	Setscrew 2x8
19	861638109	Printed circuit board B case (unit) (U.S.A.) (Canada)
	861638202	Printed circuit board B case (unit) (Australia) (UK) (Continental Europe)
20	861090000	Printed circuit board B case
21	861507108	Printed circuit board B (unit)
22	861509100	Jack cord (unit) (U.S.A.) (Canada)
	861509203	Jack cord (unit) (Australia) (UK) (Continental Europe)
23	863504008	Ferrite core (Australia) (UK) (Continental Europe)
24	000053101	Cord binder (Australia) (UK) (Continental Europe)
25	000103509	Setscrew 4x10
26	000081005	Setscrew 4x8
27	865040100	Cord guide 2
28	861640908	Switching power supply (unit) (U.S.A.) (Canada)
	861640089	Switching power supply (unit) (Australia) (UK) (Continental Europe)
29	000119704	Setscrew 3x14 (B)
30	000161206	Setscrew 3x10 (B)
31	808108007	Ferrite core (Australia) (UK) (Continental Europe)

PARTS LIST

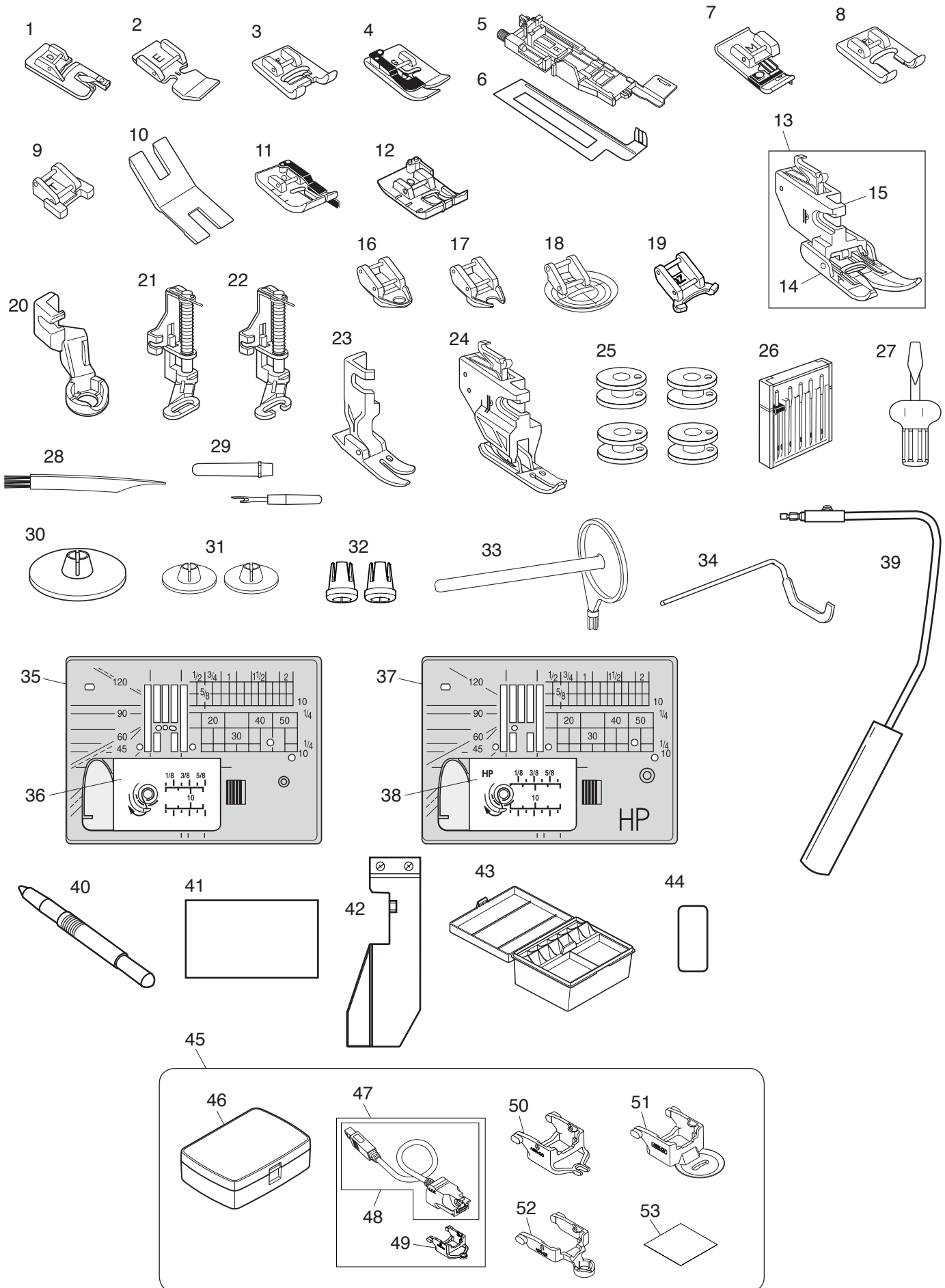

PARTS LIST

KEY NO.	PARTS NO.	DESCRIPTION
1	859804008	Rolled hem foot D
2	859805009	Zipper foot E
3	859806011	Satin stitch foot F
4	859807001	Blind hemming foot G
5	862822013	Automatic buttonhole foot R
6	859832016	Stabilizer plate
7	859810007	Overedge foot M
8	859813000	Open toe satin stitch foot F2
9	859811008	Button sewing foot T
10	832820007	Button shank plate
11	859814012	1/4" seam foot O
12	202313104	1/4" seam foot O (without guide)
13	859819017	Dual feed (twin) (unit)
14	859819109	Dual feed foot AD (twin)
15	859817015	Dual feed holder (twin)
16	859836009	Free motion quilting foot (closed-toe) QC
17	859837000	Free motion quilting foot (open-toe) QO
18	859812009	Free motion quilting foot (zigzag) QV
19	862895006	Variable zigzag open-toe foot QZ
20	862896007	Ruler work foot QR
21	859839002	Darning foot (closed-toe) PD-H
22	859839013	Darning foot (open-toe) PD-H
23	865803006	Professional grade foot HP
24	865522008	AcuFeed flex professional grade foot HP2
25	102261103	Bobbin
26	859856005	Needle case (unit)
27	820832005	Screwdriver
28	802424004	Lint brush
29	647808009	Seam ripper (buttonhole opener)
30	822020503	Spool holder (large)
31	822019509	Spool holder (small)
32	862408008	Spool holder (special)
33	809146000	Additional spool pin
34	755802001	Quilting guide bar
35	862817118	Straight stitch needle plate
36	809136100	Hook cover plate (for straight stitch needle plate)
37	865805019	Professional grade needle plate
38	809136A01	Hook cover plate (for professional grade needle plate)
39	846417022	Knee lifter
40	860194002	Touch panel stylus
41	858801002	Caution card
42	858401008	Cloth guide (unit)
43	866801007	Accessory case (unit)
44	101627A07	Threading guide sticker
45	869411108	A.S.R. case (unit) (Canada) (Australia) (UK) (Continental Europe)
46	869408009	A.S.R. case
47	868835006	A.S.R. (Accurate Stitch Regulator) with ASR-QC
48	868835017	A.S.R.
49	868837008	A.S.R. closed-toe foot ASR-QC
50	868837101	A.S.R. open-toe foot ASR-QO
51	868837204	A.S.R. clear-view foot ASR-QV
52	868837307	A.S.R. ruler work foot ASR-QR
53	103333A01	A.S.R. instruction card

PARTS LIST

1 (U.S.A.) (Canada)

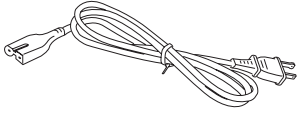

1 (Australia)

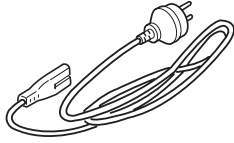

1 (UK)

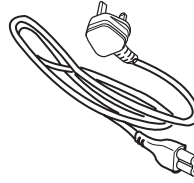

1 (Continental Europe)

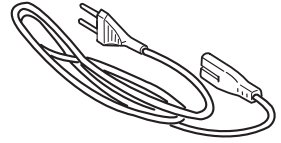

2

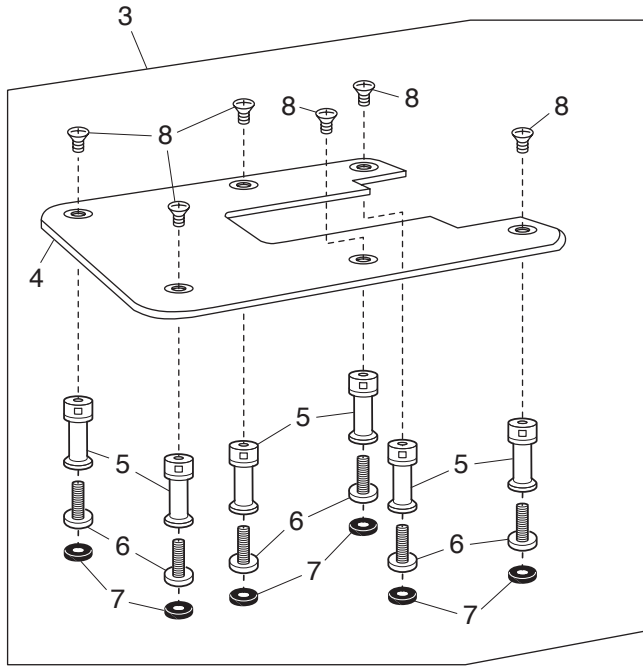
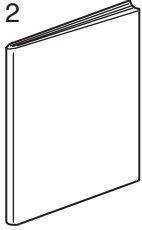

19

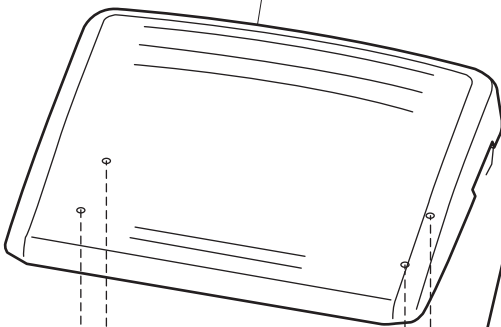

9

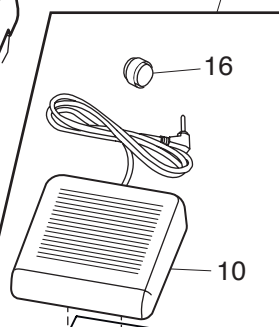

20

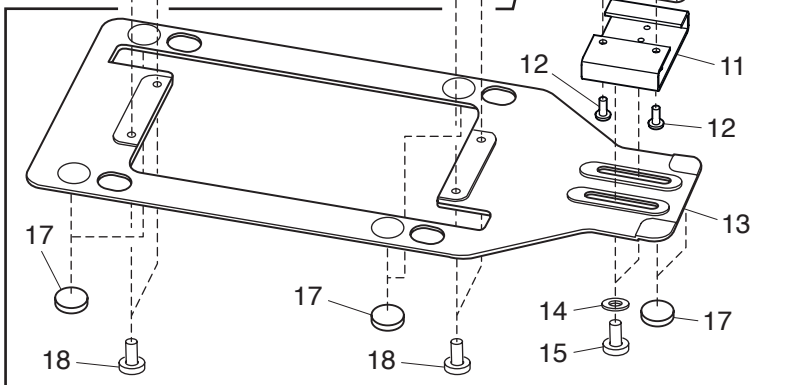
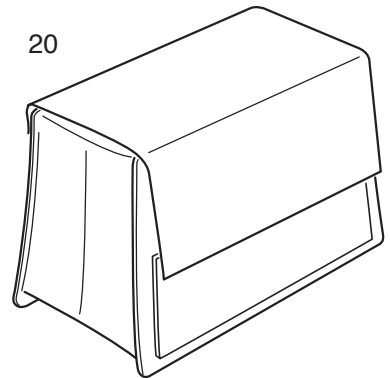

PARTS LIST

KEY NO.	PARTS NO.	DESCRIPTION
1	856519004	Power cable (U.S.A.) (Canada)
	830314018	Power cable (Australia)
	830377008	Power cable (UK)
	830335004	Power cable (Continental Europe)
2	869800005	Instruction book (English)
	869800016	Instruction book (French)
	869800038	Instruction book (German)
	869800049	Instruction book (Dutch)
3	869811009	Extra wide table (unit)
4	489011A03	Extra wide table
5	489603006	Table leg (unit)
6	489004001	Table foot
7	491002006	Rubber foot
8	000165509	Setscrew 5x18
9	865810006	Base (unit)
10	213815100	Foot switch (unit)
11	767849214	Foot switch stand
12	000198305	Setscrew 4x10 (B)
13	767849100	Base
14	000072508	Washer 4
15	865045002	Setscrew
16	767849306	Cable Tie
17	525010005	Rubber foot
18	000081005	Setscrew 4x8
19	043170108	Foot control (unit)
20	858802058	Dust cover